

electrostatic
remoistening

Top Class Remoistening

WEBMOISTER 3000

new

alfex

electrostatic
innovations

”What do you actually need
remoistening for?“

NECESSITY

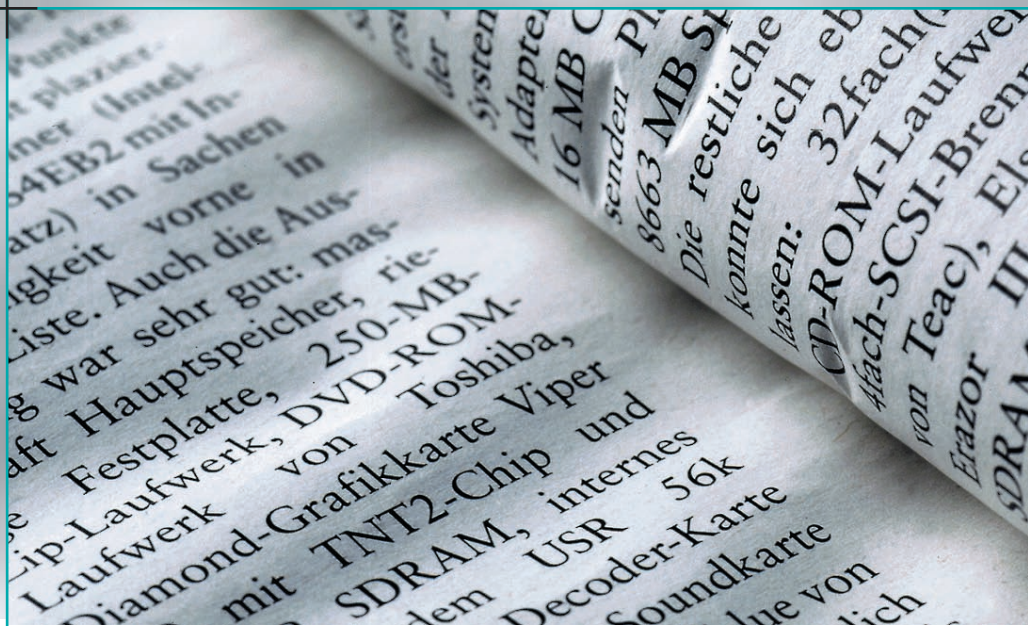

In the heatset web offset process the inks are dried with hot air. This is rapidly followed by a reduction in the water content of the paper, leading to considerable problems in the following processes. Electrostatic remoistening increases the water content in the paper after drying, returning to the level required.



**electrostatic
innovations**

”What are the advantages of remoistening?“

ADVANTAGES

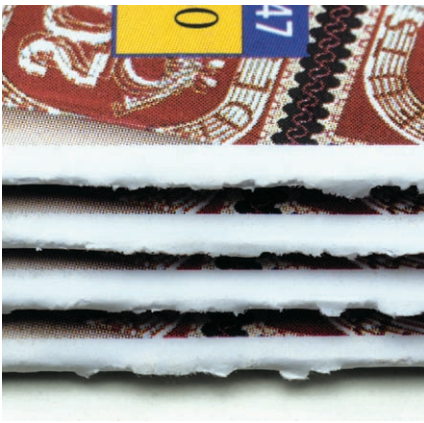

Electrostatic remoistening not only noticeably improves the quality of printed matter, but also increases productivity throughout the entire process chain.

Quality advantages

- Eliminates buckling of perfect bound cross grain products
- Prevents fibre breaking
- No growing of pages
- No climate waves (waviness)



Remoistened signatures can be mixed with signatures printed in other printing processes without any problem. The signatures lie completely flat. Problems such as inner sheets dropping of stitched printed matter or creases at the folder perforation are a thing of the past. Remoistening ensures that the paper web remains elastic and is therefore far more resistant to mechanical stress.

The economical advantages

are to be found in the improved running properties of the remoistened paper. Fewer web breaks and higher speeds in the printing press as well as in the subsequent processes mean more efficient finishing and processing.



”Can electrostatic remoistening be used with any heatset web offset press?“



FLEXIBILITY

YES.

Eltex remoistening systems can be used in all heatset web offset presses:

- small/wide presses, up to 3,000 mm
- slow-/fast running presses 6 m/s to 15 m/s
- light-weight/heavy grammages from 40 g to over 100 g/m²

The WEBMOISTER 3000 meets every requirement.

”How does electrostatic remoistening actually work?”

THE PRINCIPLE

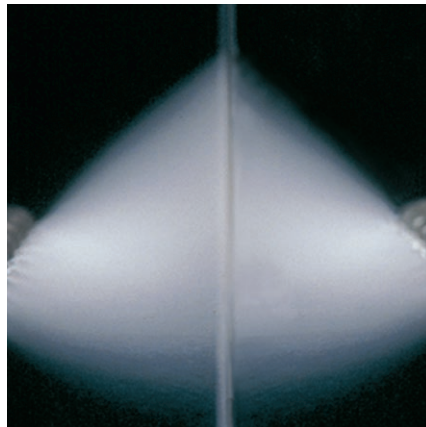

with electrostatic

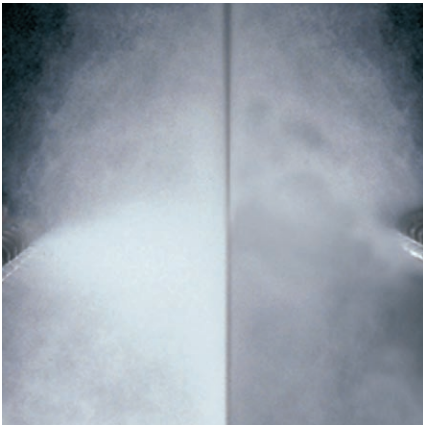

without electrostatic

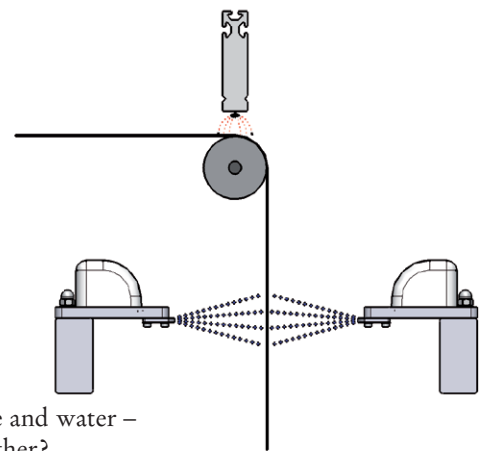

Electric voltage and water – does it go together?

Yes, it does!

It is a commonly known fact that electrostatic charge attracts dust. This effect can be exploited with water on a running paper web by the controlled generation of high voltage. A fact known by the users of over 300 Eltex remoistening systems which have been installed worldwide. The paper web is charged via a charging bar – prior to remoistening. Pneumatic atomizing nozzles arranged in opposition spray water droplets which are aligned by the electric field and accelerated in direction to the web.

The droplets hit the web in the form of finely atomized micro aerosols. Due to the characteristics of the droplets and the high voltage field, the droplets are able to overcome the air boundary layer and penetrate into the fibre structure of the paper. The water is absorbed by the substrate.



electrostatic
innovations

”How does the WEBMOISTER 3000 differ from previous models?“

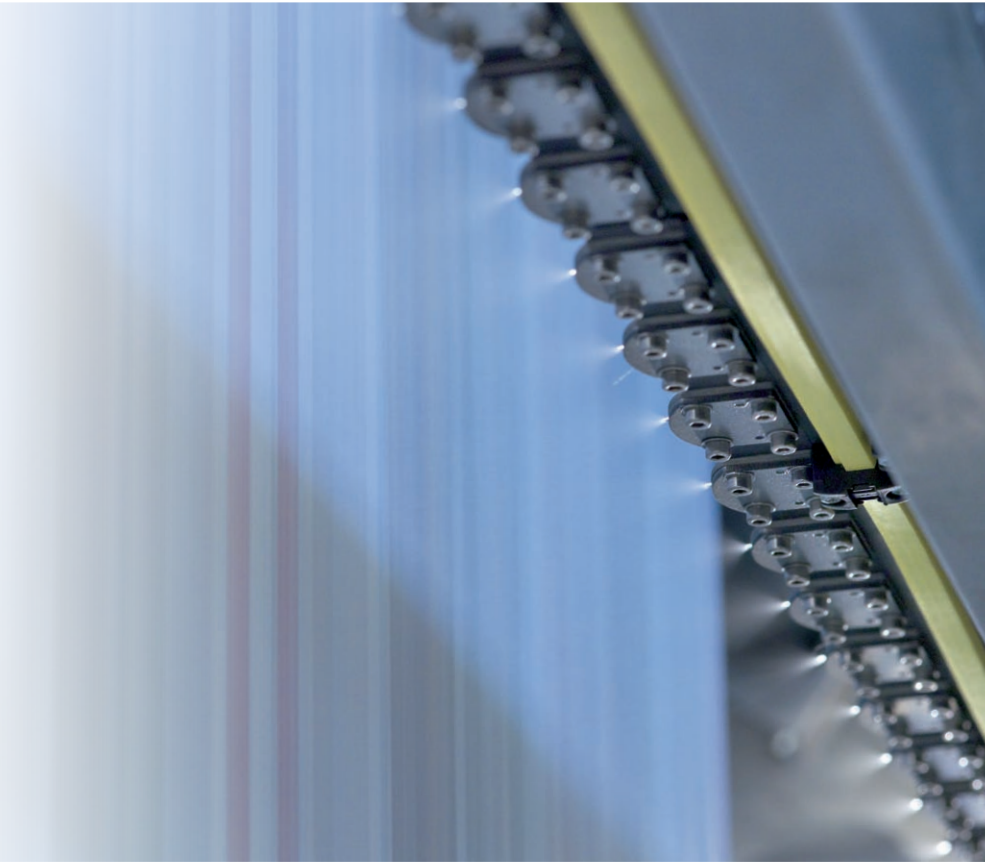

INNOVATIVE STRENGTH

Since their launch in 1989, Eltex remoistening systems have undergone continuous optimization. The objective of this further development has been to immediately incorporate new findings to offer our customers the greatest advantages at the earliest possible date.

Optimized technology by new nozzle concept

Benefits:

- no waste water
- reduced water specifications
- wider web widths
- lower operating costs



”Is the system easy to operate?“

CONTROL



The unit is operated via a new touch-screen remote control. The display provides the operator with information on the status, correct functioning and any possible faults of the system.

The operator is carefully guided through the menu via key symbols with clearly allocated functions. Only the operating symbols actually required are displayed on the screen.

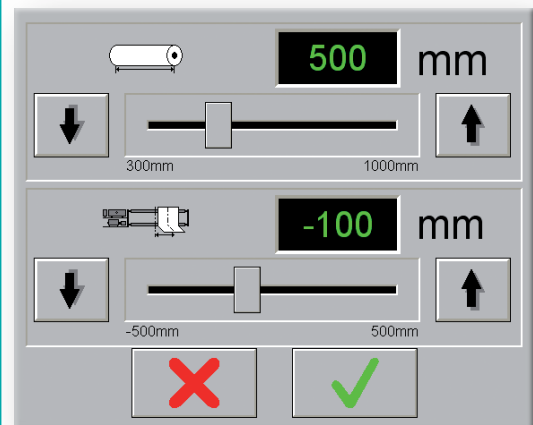

**electrostatic
innovations**

”Which elements make up the unit?“

COMPONENTS

The WEBMOISTER 3000 basically consists of three parts:

- remote control** The remote control operates via a new touch-screen monitor integrated in the press control desk or mounted directly to the remoistening system.
- base frame** The base frame includes the components of the system, the configuration of the bar, the nozzle bar and the paper web guide roller.
- control cabinet and supply modules** The control cabinet is designed for direct mounting to the base frame and includes control elements, the high voltage generator and the water supply. The pneumatic atomizing nozzles are supplied with water via a water flow controller.

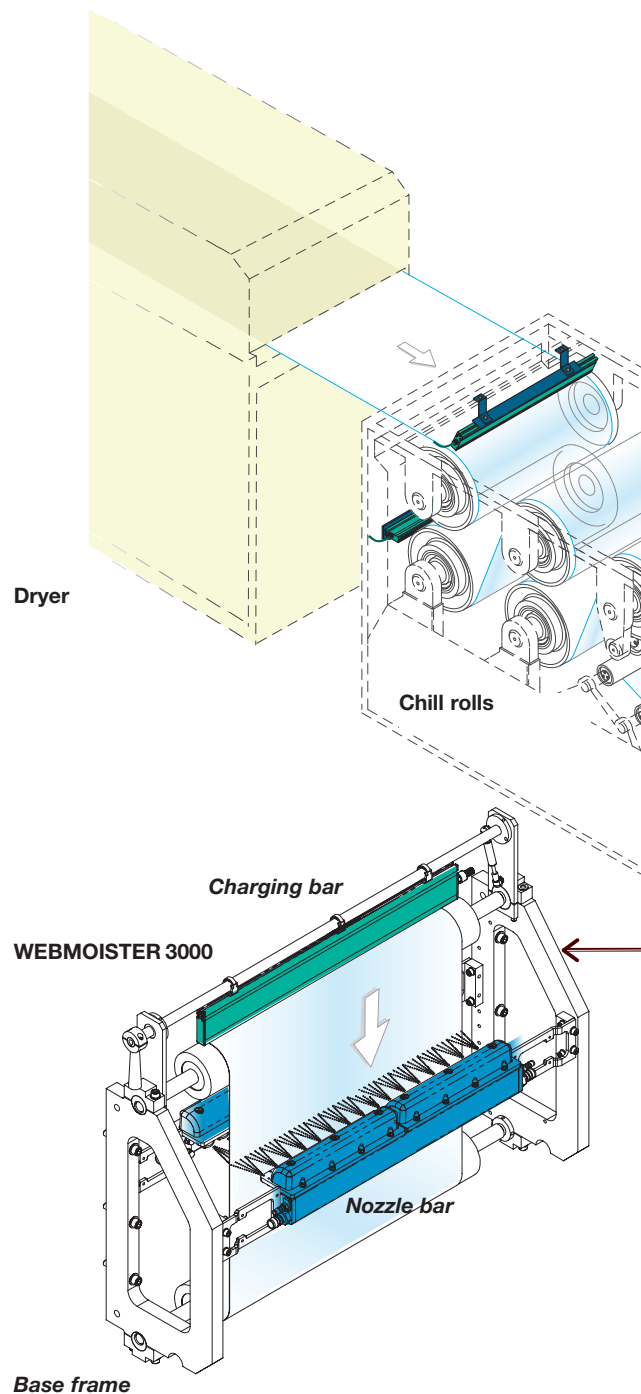

”Where is the WEBMOISTER 3000 installed?“

COMPACT

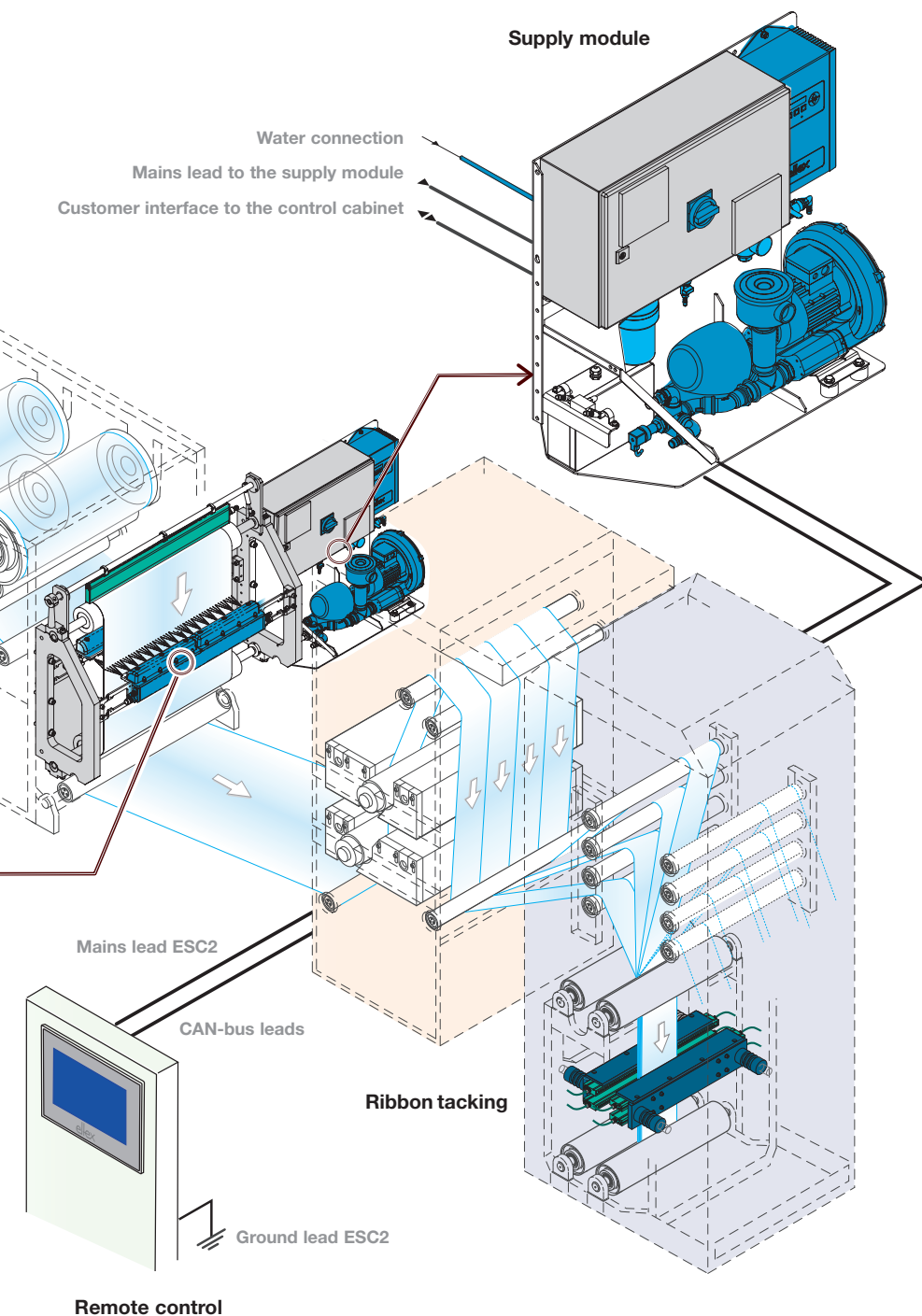

Ideally the unit is installed at the exit of the chill roll stand. If this is not possible, it may be fitted in another position between the chill rolls and the silicone applicator.



electrostatic
innovations

”Isn’t high voltage dangerous?”

SAFETY



The reliable Eltex charging bar is used to generate the high voltage field. The shockless bar guarantees an optimum field generation and field distribution. The Eltex high voltage generator supplies controlled and target-specific high voltage. This guarantees the highest degree of safety.



electrostatic
innovations

”Does the WEBMOISTER 3000
cause high operating costs?”

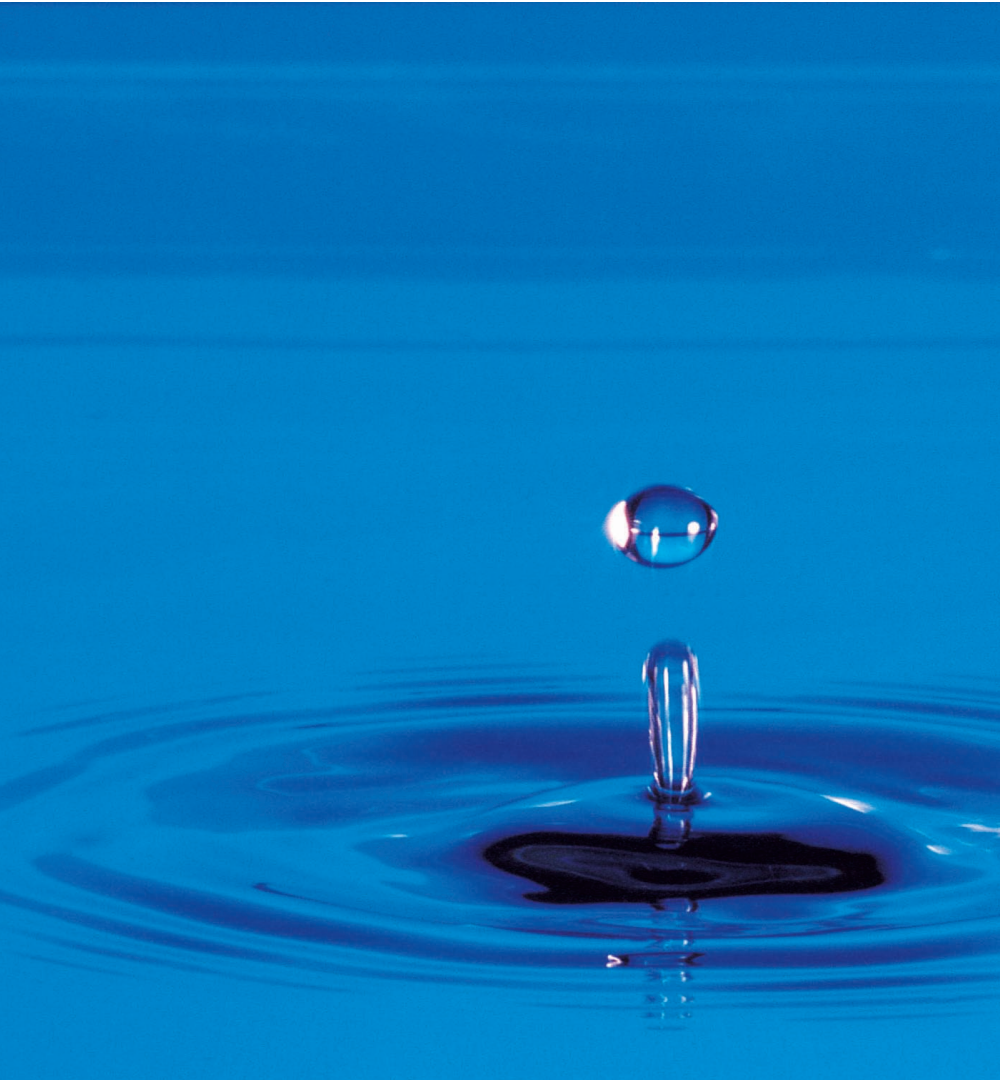

ECONOMY

Just the opposite!
The operating costs of the
WEBMOISTER 3000 are lower
than in all predecessor models.
The energy consumption is
negligible. The unit atomizes only
the quantity of water which the
paper needs; no waste water.
Maintenance costs are extremely
low.

”How much training
will our printers need
to operate the unit?“

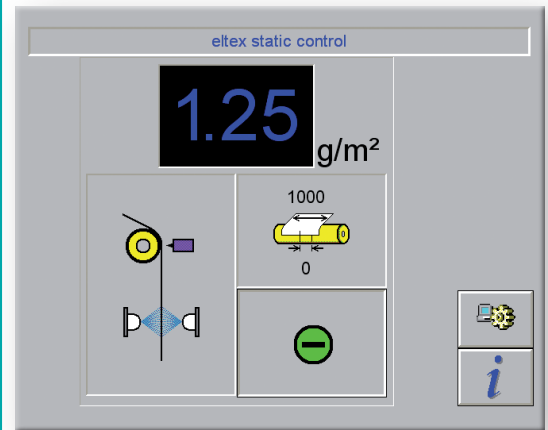
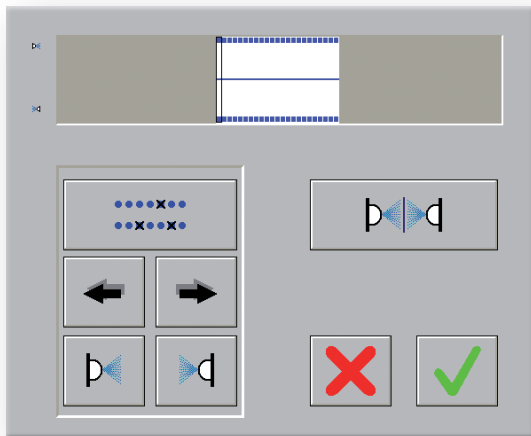

SIMPLICITY

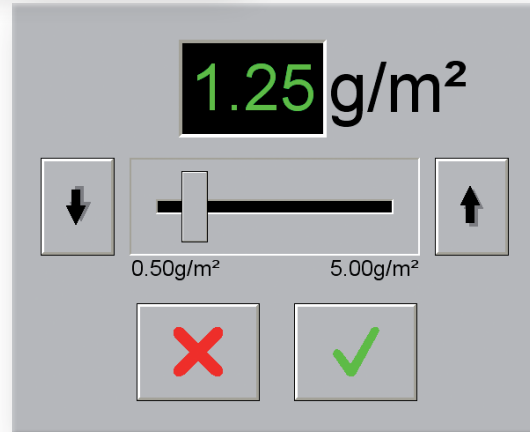

The unit is very easy to operate;
no need for complex training.
In the basic version of the remote
control, only the web width
and the desired remoistening level
need to be entered.

”How can I assess the effect
of the WEBMOISTER 3000?“

MONITORING

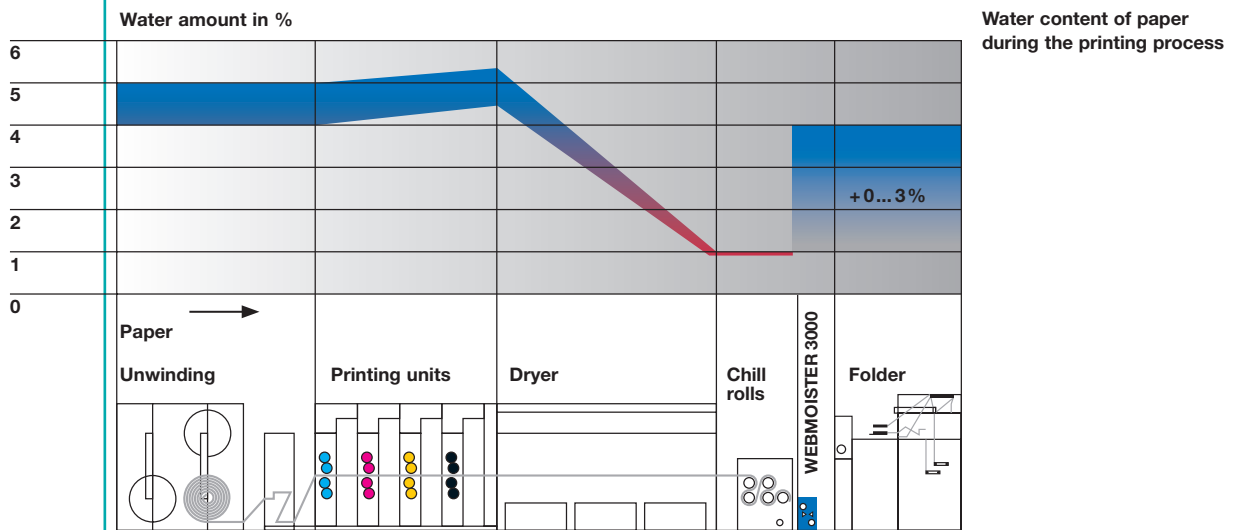

The best proof are satisfied customers who are pleased to receive top quality heatset products. In order to ensure customer satisfaction during the production process, we recommend making spot checks of the water content of the paper. The WEBMOISTER 3000 always sprays the amount needed. Moisture variations in paper are quite common and can be identified by regular measurements.

”Who uses electrostatic remoistening?”

REFERENCES



Aller
Tryk

Clausen & Bosse

manroland

LEYKAM
LET PRINT

westermann
druck

KOMORI
Kando · Beyond Expectations

B&K
OFFSETDRUCK

Mohn media
arvato



Stabilimento Italiano Alle Strefe 1961

QAP
offset alpine printing

KBA

Eltex remoistening units are used with the latest, extra-wide heatset web offset presses operating at highest production speeds, as well as on printing presses with normal web widths and speeds.

Even if the print run is rather small and it is not worth operating at maximum speeds, the WEBMOISTER 3000 achieves a homogenous and linear remoistening. Today, over 120 printing houses worldwide already appreciate the advantages of Eltex remoistening systems.

”What can we do for you?“

QUESTIONS

You still have some questions?
Don't hesitate to ask your nearest
Eltex consultant, the Product Manager
for remoistening or contact the
Eltex headquarters in Weil am Rhein.
You may also see our website
www.eltex.com for the latest information.

The desire to know what our customers
want and to find solutions for them
is what drives us on. This is the basis
of our expertise, enabling us to develop
a wide range of pioneering electrostatic
solutions and specific applications
for you. Maintenance and support
round off our range of services for your
Eltex systems.



**electrostatic
innovations**

The logo for Eltex, consisting of the word "eltex" in a white, lowercase, sans-serif font, oriented vertically within a dark blue rectangular background.

eltex

electrostatic
innovations

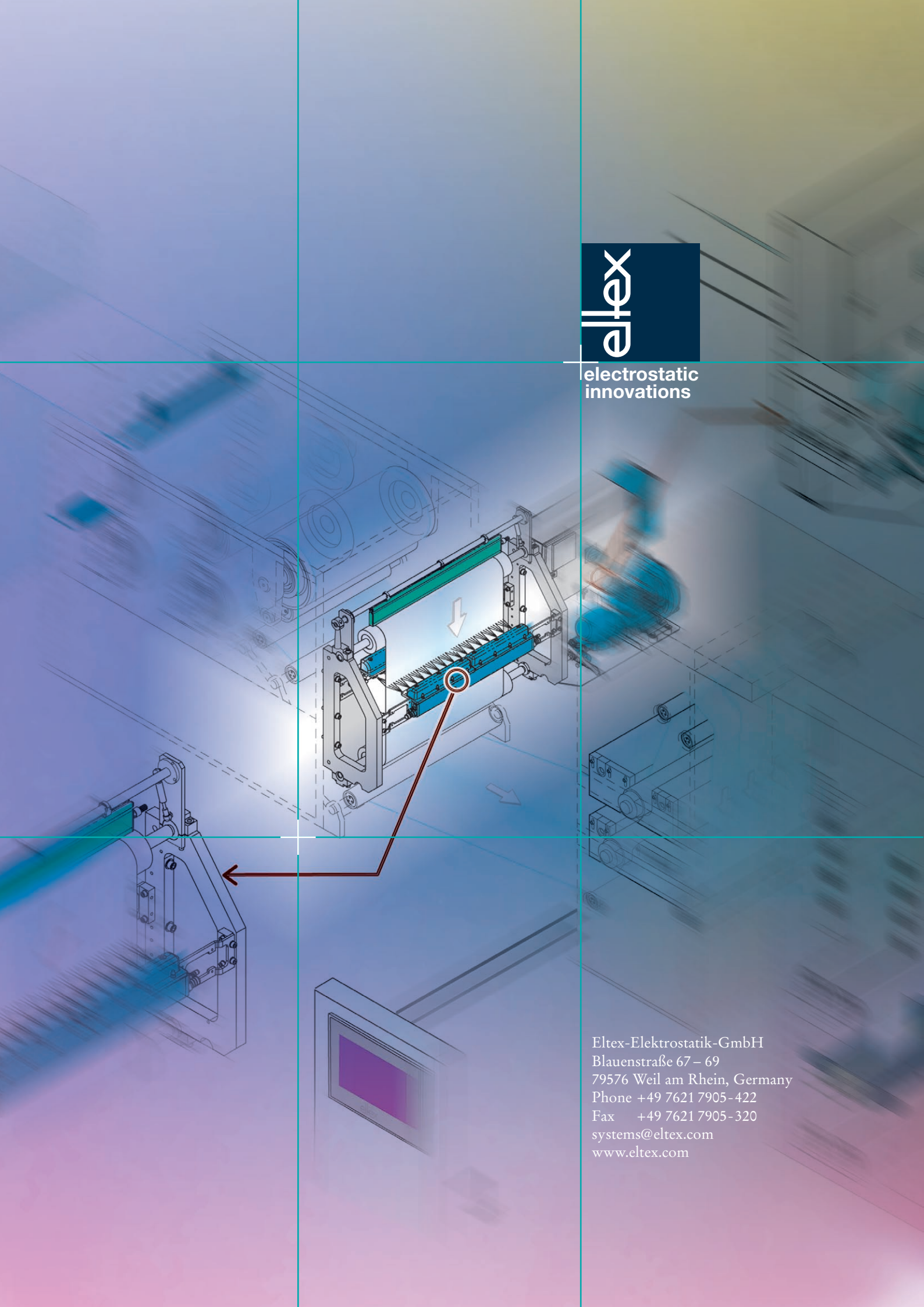

Eltex-Elektrostatik-GmbH
Blauenstraße 67 – 69
79576 Weil am Rhein, Germany
Phone +49 7621 7905-422
Fax +49 7621 7905-320
systems@eltex.com
www.eltex.com