

省力化的顧問  
**株式會社 伸興**  
 SHINKO CO., LTD.

- **總公司 HEAD OFFICE**  
 〒551-0021 大阪市大正區南恩加島5丁目8-84 TEL:+81 6-6552-3170(總機)  
 8-84, 5-chome, Minami-Okajima, Taishou-ku, Osaka, 551-0021, Japan  
 工廠 TEL:+81 6-6553-1062 FAX:+81 6-6554-4074  
 營業部 TEL:+81 6-6552-3171 FAX:+81 6-6552-3371 E-mail:osaka@shinko-jp.biz
- **東京分公司 TOKYO BRANCH**  
 〒140-0004 東京都品川區南品川2-2-5 REID-C南品川Building  
 2-5, 2-chome, MinamiShinagawa, Shinagawa-ku, Tokyo, 140-0004  
 TEL:+81 3-3474-3961(總機) FAX:+81 3-3474-4969 E-mail:tokyo@shinko-jp.biz
- **名古屋分公司 NAGOYA BRANCH**  
 〒463-0072 名古屋守山區金屋1丁目8-7  
 8-7, 1-chome, Kanaya, Moriyama-ku, Nagoya, 463-0072  
 TEL:+81 52-794-2820(總機) FAX:+81 52-794-1280 E-mail:nagoya@shinko-jp.biz
- **四國營業所 SHIKOKU OFFICE**  
 〒763-0082 香川縣丸龜市土器町東3丁目589  
 589, 3-chome, Higashi, Doki-cho, Marugame, Kagawa Pref, 763-0082  
 TEL:+81 877-25-3655(總機) FAX:+81 877-25-3797 E-mail:shikoku@shinko-jp.biz
- **富士營業所 FUJI OFFICE**  
 〒417-0047 靜岡縣富士市青島町220  
 220, Aoshima-cho, Fuji, Shizuoka Pref, 417-0047  
 TEL:+81 545-51-7981(總機) FAX:+81 545-51-7982 E-mail:fuji@shinko-jp.biz
- **京滋營業所 KEIJI OFFICE**  
 〒607-8041 京都市山科區四之宮垣之内町2 四之宮Court  
 2, Kakinouchi-cho, Shinomiya, Yamasina-ku, Kyoto, 607-8041  
 TEL:+81 75-591-7535(總機) FAX:+81 75-591-7721 E-mail:keiji@shinko-jp.biz
- **北關東營業所 KITAKANTO OFFICE**  
 〒343-0826 埼玉縣越谷市東町2丁目120-1 松島Building  
 120-1, 2-chome, Azuma-cho, Koshigaya, Saitama Pref, 343-0826  
 TEL:+81 48-971-5411(總機) FAX:+81 48-971-5439 E-mail:kitakanto@shinko-jp.biz
- **廣島營業所 HIROSHIMA OFFICE**  
 〒731-0113 廣島縣廣島市安佐南區西原6丁目9-42 Gran Via西原101  
 9-42, 6-chome, Nishihara, Asaminami-ku, Hiroshima, 731-0113  
 TEL:+81 82-225-6353(總機) FAX:+81 82-225-6773 E-mail:hiroshima@shinko-jp.biz

- **OVERSEAS OFFICE**
  - **SHINKO TAIWAN (Taiwan)**  
 E-mail: s.chen@shinko-jp.biz
  - **SHINKO TECH (Korea)**  
 Gwanggyo Maulro 11, Suji-Gu, Yongin City, Gyeonggi-Do, Korea  
 TEL:+82 31-261-5677 FAX:+82 31-261-6957 E-mail: sk04korea@hanmail.net
  - **SHINKO EUROPE AG (Europe)**  
 Mattenstrasse 6, 3073 Gümligen, Switzerland  
 TEL:+41 31-917-1044  
 E-mail: info@shinko-europe.ch Website: http://www.shinko-jp.biz/english/
  - **OVERSEAS AGENT**
  - **KOREA :**
  - **DONG IL TECHNO TRADING**  
 3F Dae Gwang Bldg. 150, Dogok-ro, Gangnam-gu, Seoul  
 TEL:+82 2-508-0962 FAX:+82 2-567-4505  
 E-mail: dongiltrade@naver.com Website: http://www.dongiltrad.com
  - **SUNGLIM TECH CO.,LTD.**  
 5F, 61, Banpo-daero 30-gil, Seocho-gu, Seoul, 137-874, Korea  
 TEL:+82 2-586-0325 FAX:+82 2-587-0515  
 E-mail: sunglimtech@sunglimtech.com Website: http://www.sunglimtech.com
  - **CHINA :**
  - **BEIJING KLN TECHNOLOGY DEVELOPMENT CO.,LTD.**  
 Room 8188, Building 1-1, No.28 A, Fengguan Road, Fengtai District, Beijing, 100071, China  
 TEL:+86-157-1134-5686 E-mail: gaopeng@kln-bj.com Website: http://www.kln-bj.com
  - **BEIJING TSTD OPTOELECTRONICS TECHNOLOGY CO.,LTD.**  
 NO.61, Jinma North Street, Mafang Town, Pinggu, Beijing  
 TEL:+86-180-0119-3782 E-mail: wangjuan@bjtsd.com.cn
  - **TAIWAN :**
  - **KIGENG TRADING CO.,LTD.**  
 6F, No.405, Sec. 2, Zhongshan Rd., Zhonghe Dist., New Taipei City 235, Taiwan  
 TEL:+886-2-2225-7688 E-mail: sales@kigeng.com.tw
- 株式會社 伸興 官方網站 ● Website: http://www.shinko-jp.biz ● E-mail: kanri@shinko-jp.biz

代理店

### ⚠ 產品安全須知

- 為了正確安全使用本產品，使用前請務必詳閱「操作說明書」。
- 本產品並非以會危及生命的情況下使用之機器為目的設計、製造。
- 本產品在嚴密的品質管理下製造，但在可預測的會因本產品故障而產生重大事故或損失的設備上使用，請設置安全裝置。

此印刷刊物為2023年9月發行，請注意，部分規格可能會有所更改。

非接觸式  
**NON-CONTACT**

# 超音波乾式除塵裝置

ULTRA SONIC CLEANER

- UVU-W
- VUV-W
- VUV-HGv-W
- SA
- Vacuum Cleaner
- NSHV-W
- Brush Cleaner
- TURBO-SS

防爆型靜電消除裝置  
 Explosion Proof Ionizer

# UVU-W TYPE & NEW UVU-W-HE TYPE

採用新型高效率除塵頭  
New Type High-Efficiency Head Adopted

可100%除去6μm粉塵 100% Removal of 1.6μm particles.

## 超越微觀極限的除塵能力

Particle Removing Capacity Beyond the Limits of the Microscopic World.

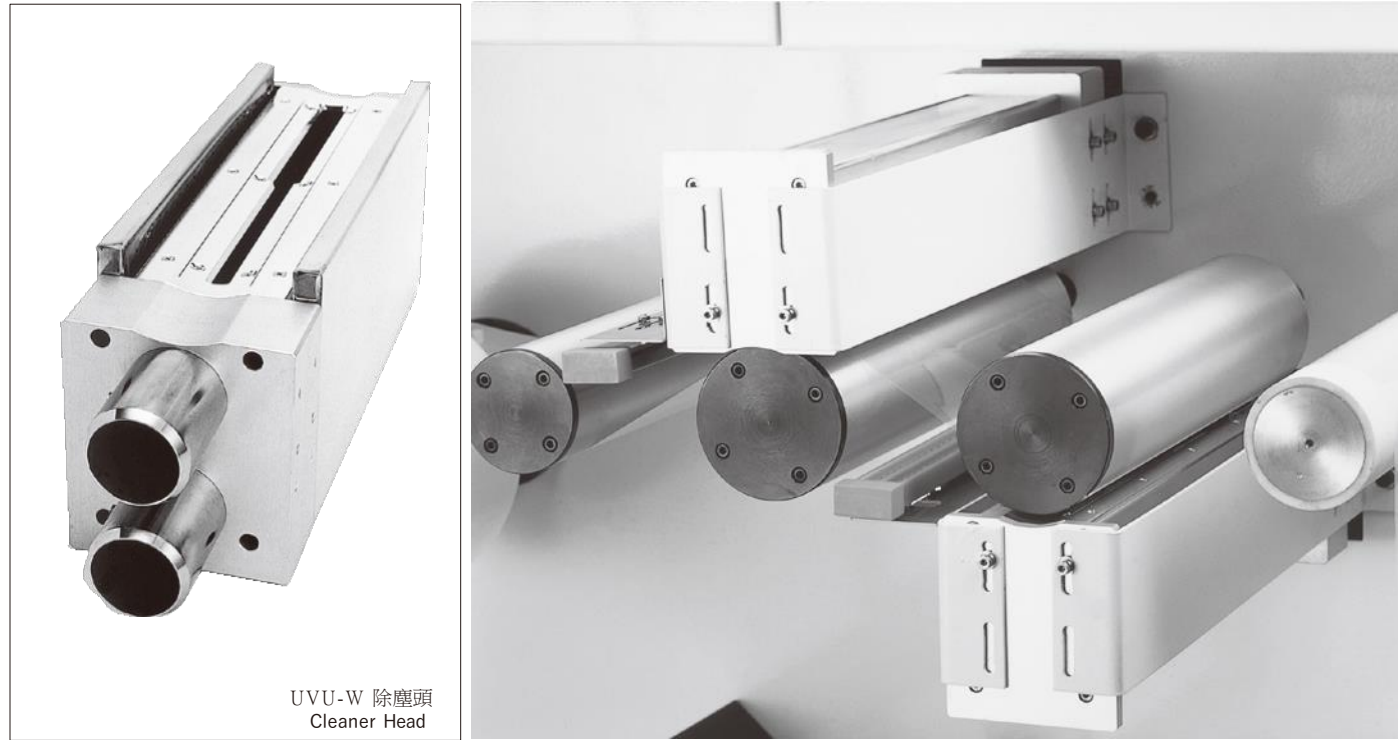

UVU-W 除塵頭  
Cleaner Head

### 1. UVU-W (Web用) 概要 Concept (for web applications)

新型乾式除塵裝置 (UVU-W) 採用橫斷面「Ultrasonic Pressure · Vacuum · Ultrasonic Pressure」排列的專利構造，是有著超越以往的非接觸式乾式除塵裝置，世界最強極限的性能除塵裝置。

New UVU-W cleaner with a patented [Ultrasonic Pressure, Vacuum, Ultrasonic Pressure] design provides most unparalleled cleaning effectiveness.

### 2. 基本特長與 UVU 式效果 Features and Benefits

- 1) 可 100% 除去 1.6 μm 粉塵。(公司內部無塵室測試)
  - 2) 新型的多波超音波發生器的波形具有多個峰值，其平均輸出提高了約 20 dB，使其對任何形狀的灰塵都有效。
  - 3) 超音波空氣碰撞產生的亂流促進粉塵邊界層的破壞，有助於粉塵的分離。
  - 4) 2 個方位的風向可以對各種附著狀態的粉塵發揮最大效果。(參考圖-2)
  - 5) 憑藉新型除塵頭的高強度本體及我獨特的加工技術，可以加工出比以往更細、幅度更均一的狹縫，使超音波、氣刀效果在噴嘴有效長度內的輸出更均一，無除塵不均勻之情況。
- I. 100% removal of particles down to 1.6 μm.
  - II. Many wave peaks produced by multi-wave ultrasonic generator, together with a high average output level of 132.8dB, contribute to removing particles regardless of their shapes.
  - III. Turbulent flow caused by collision of ultrasonic waves helps to break the boundary layer and separate trapped particles.
  - IV. Bi-directional air flow efficiently removes particles regardless of their orientation on the web (see Fig. 2)
  - V. High rigidity of the new head and our own original processing technology enable finer and more uniform slit gap processing and, consequent uniform output of ultrasonic wave air knife effects along the nozzle effective length ensures no irregularity of dust removal.

**NEW** 高效率除塵裝置  
(UVU-W-HE 型)  
High-Efficiency System  
(UVU-W-HE Type)

提高除塵頭的效率，可以使用更少的風量來達到與以往同等性能的清潔效果。因此可以使用較小容量的鼓風機，降低運行成本。

By enhanced efficiency of cleaner head, required air flow volume for cleaning can be less than that of our previous types. Needless to say, by keeping the same performance of these conventional types. Hence, smaller blower capacity and cost reduction can be planned.

(圖-1) 結構圖  
(Fig.1) Structure

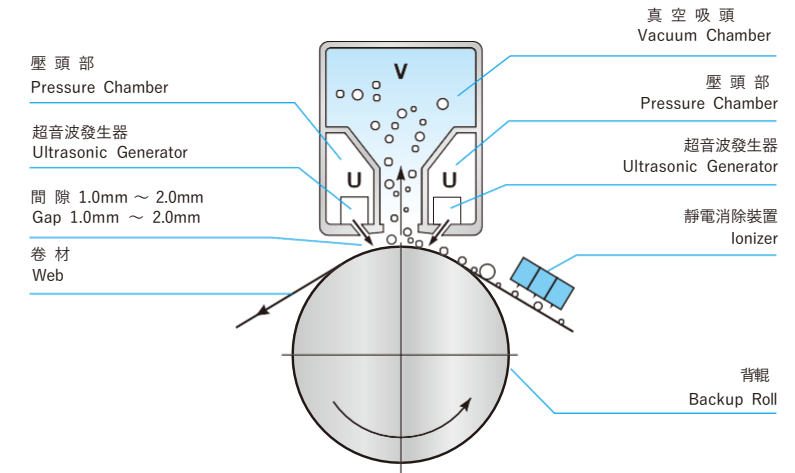

(圖-2) 除塵效果  
(Fig.2) Particle Removal

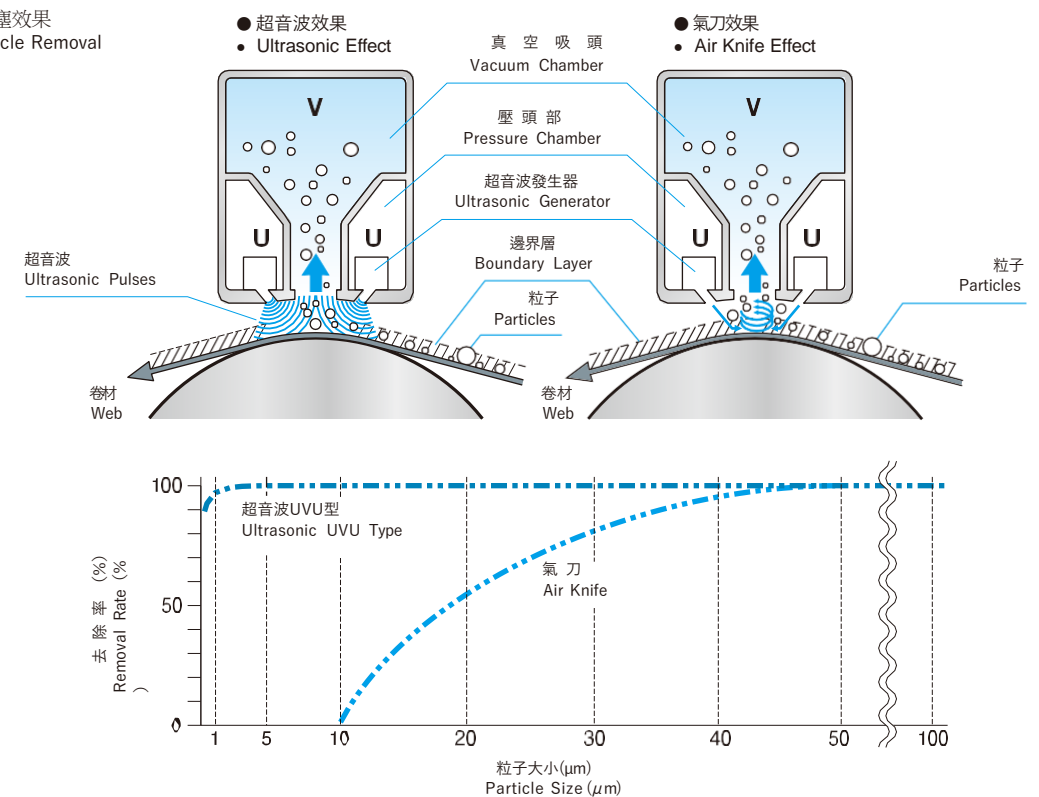

### 3. 除塵原理 Principle

新型乾式吸塵頭由內建超音波發生器的壓頭部及吸除粉塵的真空吸頭組成。(參考圖-1) 從壓頭噴出的高速空氣變成超音波高速氣刀吹拂卷材表面。一般粗大粉塵(50 ~ 100μm以上) 可以藉由高速空氣氣刀從卷材表面剝離下來，但是卷材表面上的空氣高速流動令卷材表面附著的微粒子塵因邊界層強固而除塵困難。超音波可破壞邊界層，有效使微粒子塵從卷材表面剝離。換言之，高速空氣上附加的超音波的振動能量能破壞邊界層，使卷材表面的微粒子剝離。且超音波藉由氣刀作用也可助長粗大粉塵的游離效果。如上所述，高速空氣藉由氣刀效果和超音波效果把從粗大粉塵到微粒子塵的粉塵從卷材表面剝離，再經真空吸頭吸引有效除去粉塵。(參考圖-2)

The cleaning heads are designed with dual ultrasonic pressure nozzles and a large vacuum slot to remove small and large particles. (see Fig.1) Dual high pressure air nozzles, produce a high velocity air knife effect to remove larger particles, 50 to 100 microns. These particles are then sucked into the vacuum slot from both directions and removed. However, a viscous boundary layer is formed on the surface of the web because the air flows at a high velocity above the viscous layer. Ultrasonic pressure pulses separate small particles that are confined in the viscous layer. In other words, an ultrasonic pressure energy transferred in high velocity air stream destroys the boundary layer to free the small particles from the web surface. Small particles as well as large particles are effectively sucked away through the vacuum head after they are separated from the web surface by the combined effects of air-knife impact and ultrasonic waves and removed by a high velocity vacuum. (see Fig. 2)

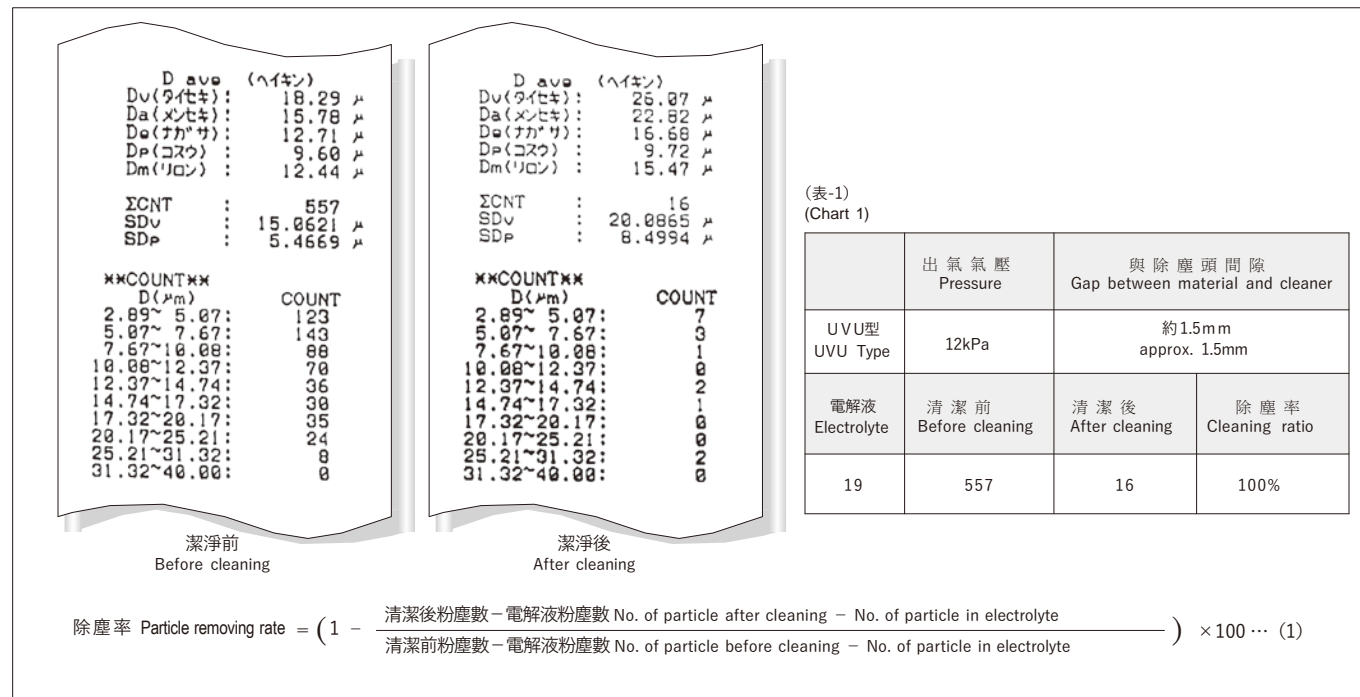

#### 4. 除塵測試範例與結果 Examples of cleaning test results

##### 測試條件-1

- 基材：PET薄膜
- 粉塵：環境粉塵
- 產線速度：200m/min

##### Test 1

- Material: PET film
- Particles: Floating particle
- Line speed: 200m/min.

##### 評估方法

顆粒計數器比較清潔前後採樣薄膜上的灰塵顆粒數量，以評估除塵能力。表-1 顯示資料列表範例。  
ΣCNT表示粉塵總數、\*\*COUNT\*\*依粒子大小表示粉塵數。

##### Evaluation

The numbers of particles on a film base were sampled and counted before and after cleaning and compared. The result determines cleaning performance. The results are shown on the data sheet, Chart 1. (CNT shows the total number of counted particles. \*\*COUNT\*\* shows the number of particles by size.)

##### 評估結果

除塵能力以式(1)所示除塵率表示。另外，測試結果（除塵率）如表-1表示。

##### Results

Cleaning performance is determined by equation (1) which calculates the particle removal ratio. The test result is shown in Chart 1.

##### 測試條件-2

- 基材：液晶用玻璃基板 (360mm x 470mm x 0.4t)
- 粉塵：1.6µm樹脂微粒 (乾式散佈)
- 運送速度：100mm/sec.
- 評估方式：表面檢查裝置 (GI-4830)

##### Test 2

- Material: LCD glass (360mm x 470mm x 0.4t)
- Particles: 1.6 micron spacer beads
- Line speed: 100 mm/sec.
- Evaluation method: surface inspection device (GI-4830)

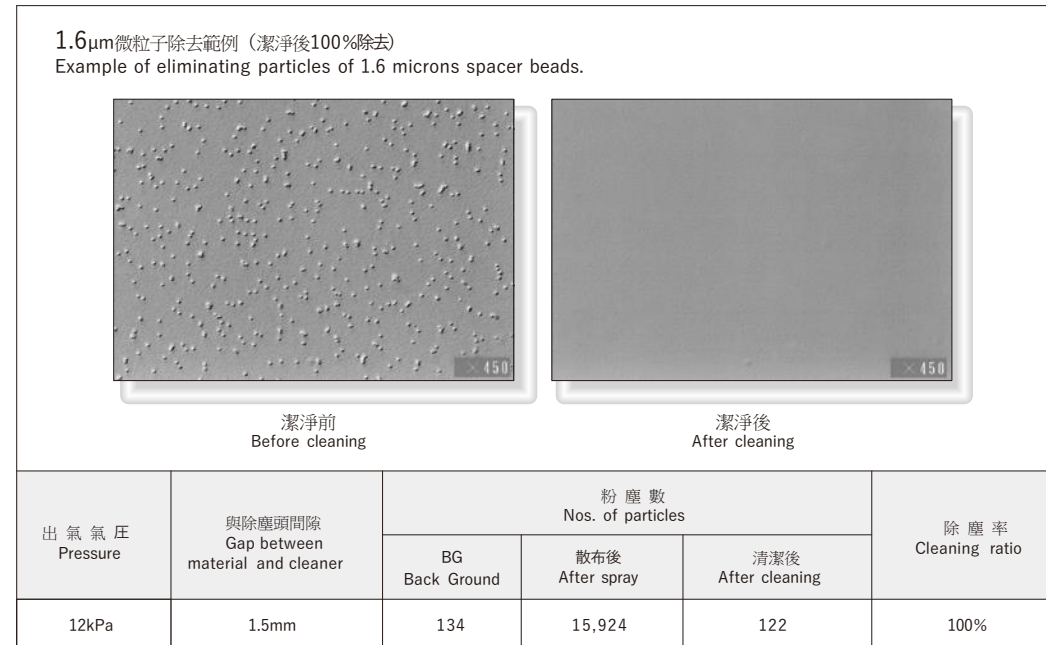

注) 測試結果是在伸與無塵室內測試得到的數據，可能會因客戶無塵室的環境、顆粒類型、測試條件等而有所不同。  
This test data is a referential data for the test carried out at SHINKO clean room. Test results vary according to particle types, test environment, test condition and etc.

## VUV-W TYPE & NEW VUV-W-HE TYPE

採用新型高效率除塵頭  
New Type High-Efficiency Head Adopted

可100%除去3µm粉塵 100% Removal of 3µm particles.

### 1. VUV-W概要 Concept

VUV-W卷材除塵裝置是採用橫斷面 Vacuum / Ultrasonic Pressure / Vacuum 排列之構造。

中央為出氣部而其兩側為真空吸嘴的平衡設置，可以減小鼓風機容量配置，減低初期成本及運行成本。

UVU-W web cleaner adopts section structure arranged as Vacuum/Ultrasonic Pressure/Vacuum. Well-balanced placing suction nozzles at both sides of the center discharge portion enables mitigation of air leak, which could reduce blower capacity and then substantially decreased both costs in initial and running.

### 2. 特色・效果 Features

1. 可100%除去3µm粉塵的乾式除塵裝置。
2. 使用新開發的高效率除塵頭，可以配置比從前更小容量的鼓風機。
3. 中央以超音波氣刀吹拂而其兩側為真空吸頭的平衡構造，有更好的清潔效率。
4. 可以節省鼓風機室的空間。
5. 因為是乾式潔淨，故無需液體交換作業或乾燥工程，可以節約設備或運行成本。
6. 超音波在有效長度內均一地從噴嘴輸出，無除塵不均勻情況。
7. 超音波發生裝置為半永久性，不會有性能劣化的情況。
8. 非接觸式，故不會對基材表面造成損傷。

- i. By dry cleaning method, 100% elimination of 3µm dust can be performed.
- ii. We developed and adopted then high efficiency head, and now can use blowers of less air flow volume than those of our previous types.
- iii. The structure of blowing ultrasonic air knife at the center and vacuuming in well-balanced conditions at both sides does decrease air leak and perform cleaning efficiently.
- iv. Blower space is compact and require low cost.
- v. Dry cleaning method does not need any fluid exchange work or process to dry, which require less cost in equipment investment and for daily operation.
- vi. Uniform output of ultrasonic wave along nozzle effective length provides dust removability in an even condition.
- vii. Ultrasonic wave generating device will not suffer performance deterioration almost permanently.
- viii. Non-contact cleaning does not cause damage on the substrate surface.

(圖-1) 結構圖 (Fig.1) Structure

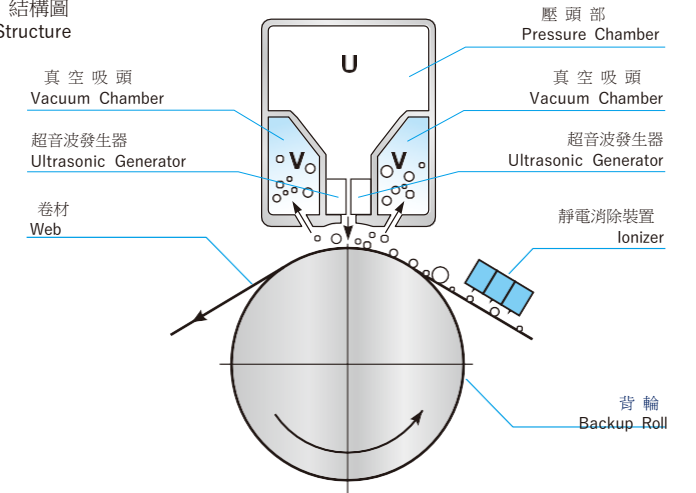

除塵測試 Cleaning Test ● 基材：PET薄膜 ● 粉塵：環境粉塵 ● 產線速度：200m/min  
● Substrate: PET film ● Particles: Environmental dust ● Line speed: 200m/min

3µm的微粒子除去範圍 (潔淨後100%除去)  
Particles of 3µm spacer beads were entirely removed.

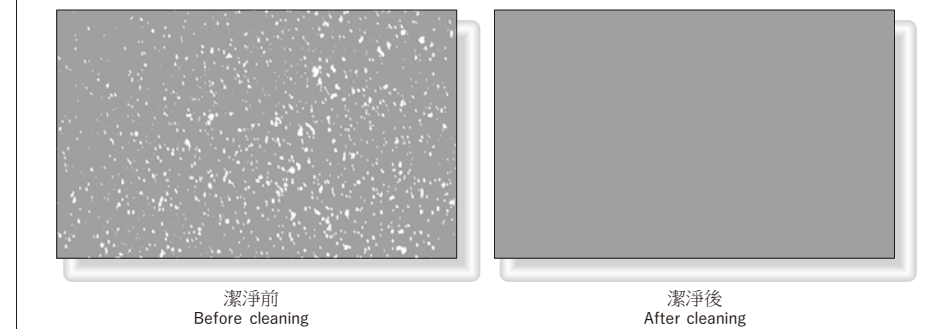

	出氣氣壓 Pressure	與除塵頭間隙 Gap between material and cleaner	電解液 Electrolyte	清潔前 Before cleaning	清潔後 After cleaning
VUV型 VUV Type	12kPa	約1.5mm approx. 1.5mm	19	557	35

注) 測試結果是在伸與無塵室內測試得到的數據，可能會因客戶無塵室的環境、顆粒類型、測試條件等而有所不同。  
This test data is a reference data for the test carried out at SHINKO clean room. Test results varies according to particle types, test environments, test conditions and etc.

### 3. 除塵原理 Principle

以超音波氣刀破壞微粒子塵的邊界層使其剝離去除之原理與UVU-W 式相同。可基於除塵基材、場所等諸多要素選擇最適合的除塵方式。

It is same as UVU-W about the principle that an ultrasonic wave air knife strips and removes fine particle dust from the boundary layer. Depending on the substrate subject to removal of dust, locations and other elements, an optimum method can be selected.

**NEW** 高效率除塵裝置  
(VUV-W-HE 型)  
High-Efficiency System  
(VUV-W-HE Type)

提高除塵頭的效率，可以使用更少的風量來達到與以往同等性能的清潔效果。因此可以使用較小容量的鼓風機，降低運行成本。

By enhanced efficiency of cleaner head, required air flow volume for cleaning can be less than that of our previous types. Needless to say, by keeping the same performance of these conventional types. Hence, smaller blower capacity and cost reduction can be planned.

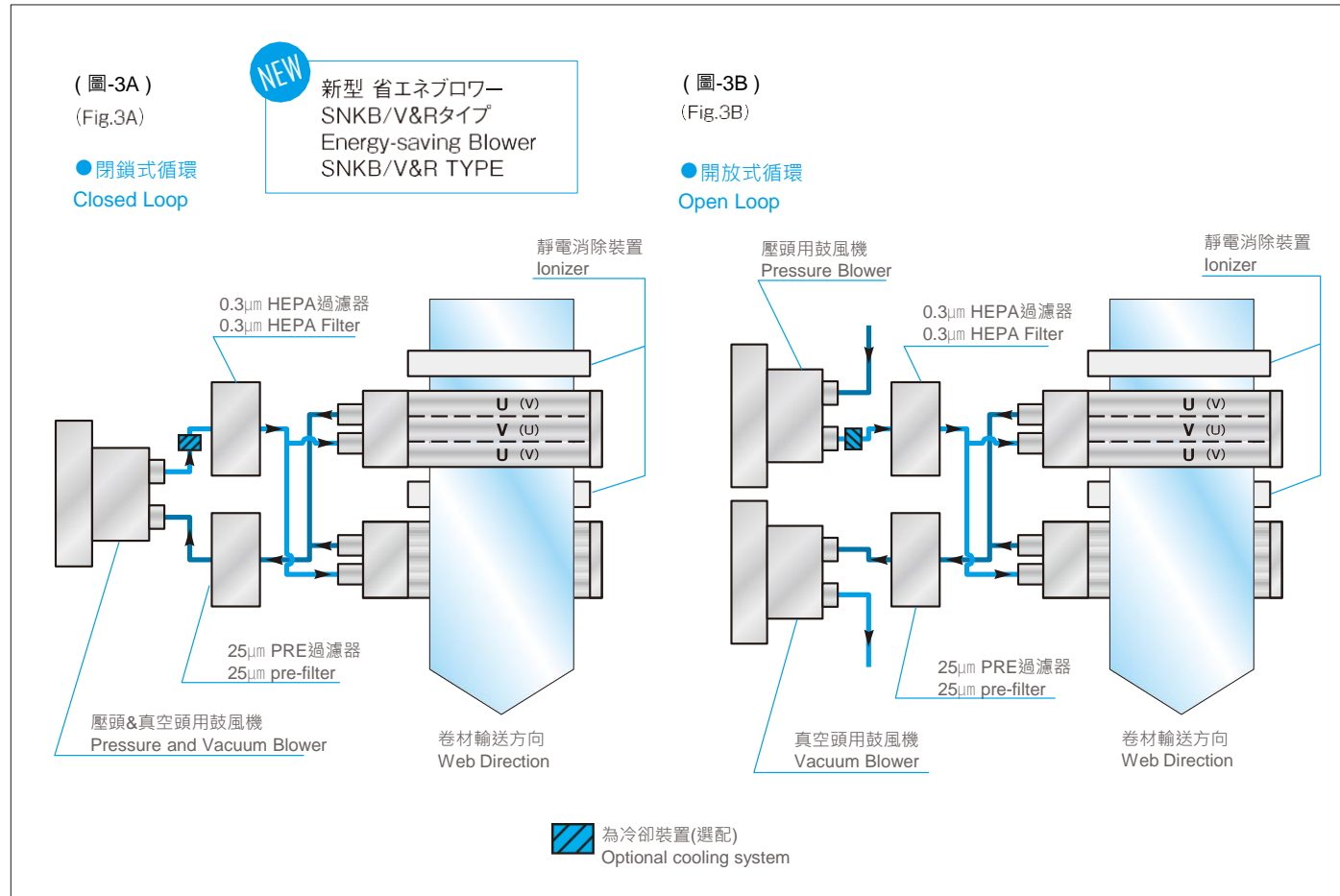

1) 全體構造 Overall System

本系統是由吸塵頭、壓頭及真空頭空氣源之鼓風機、淨化供給給吸塵頭之高速空氣的HEPA過濾器、捕捉收集吸塵頭吸收之粉塵的PRE過濾器、風量(壓力)調節閥以及將各部件連結起來的管線所構成。

This system consists of Cleaner Head, Blower, which is air supply source of Pressure (positive pressure) and Vacuum, HEPA Filter which purifies high-pressure air supplied into cleaner head, PRE Filter which captures and collects the dust sucked from cleaner head, Dumper and piping system including Hose, Pipe and etc.

2) 閉鎖式循環與開放式循環(參考圖-3A、圖-3B) Closed Loop System and Open Loop System (see Fig.3A and Fig.3B)

UVU-W的管線系統有分為閉鎖式循環及開放式循環。  
閉鎖式循環為1台鼓風機供給高速空氣並具備真空吸塵機能的空氣循環配置。此方式將空氣循環利用，故不會破壞無塵室的空氣平衡，設備成本也較低。但鼓風機加壓空氣時會造成空氣溫度上升，故須留意散熱條件及基材是否容易受溫度影響。  
開放式循環系統因其分別有壓頭用鼓風機及真空頭用鼓風機，故空氣溫度比起閉鎖式較不容易上升。

Regarding UVU-W piping system, there are two types: closed loop system and open loop system. Closed loop system is a circulatory piping system which has a blower used to supply high-speed air and to vacuum particle dust at the same time. This circulatory system does not lose air balance within the room like as a clean room where the system is installed, and equipment cost is low. As temperature increases when the blower pressure is raised, careful attention is required for dissipation conditions and about the web which is commonly affected by temperature.  
Open loop system has different blowers for Pressure and Vacuum respectively, which moderates temperature increase of air compared with the closed loop system.

3) 選配 Option

- 為使系統能在最佳的條件下運行 也提供以下的選配設備。
- 靜電消除設備 ●吸塵頭升降設備 ●鼓風機單元 (包含鼓風機、過濾器設備的一體型架台) ●集塵器 (粉塵較多導致過濾器過早堵塞時使用)
  - 冷卻裝置 ●隔音罩
- The following devices are available for the customers to use the system for better conditions:  
●Ionizer to eliminate electrostatic charge ●Cleaner head lifter ●Blower unit (Integrated mounting unit including a blower and a filter)  
●Dust collector (To be used when filter is clogged fast with plenty of dust) ●Cooling system ●Silencer cover

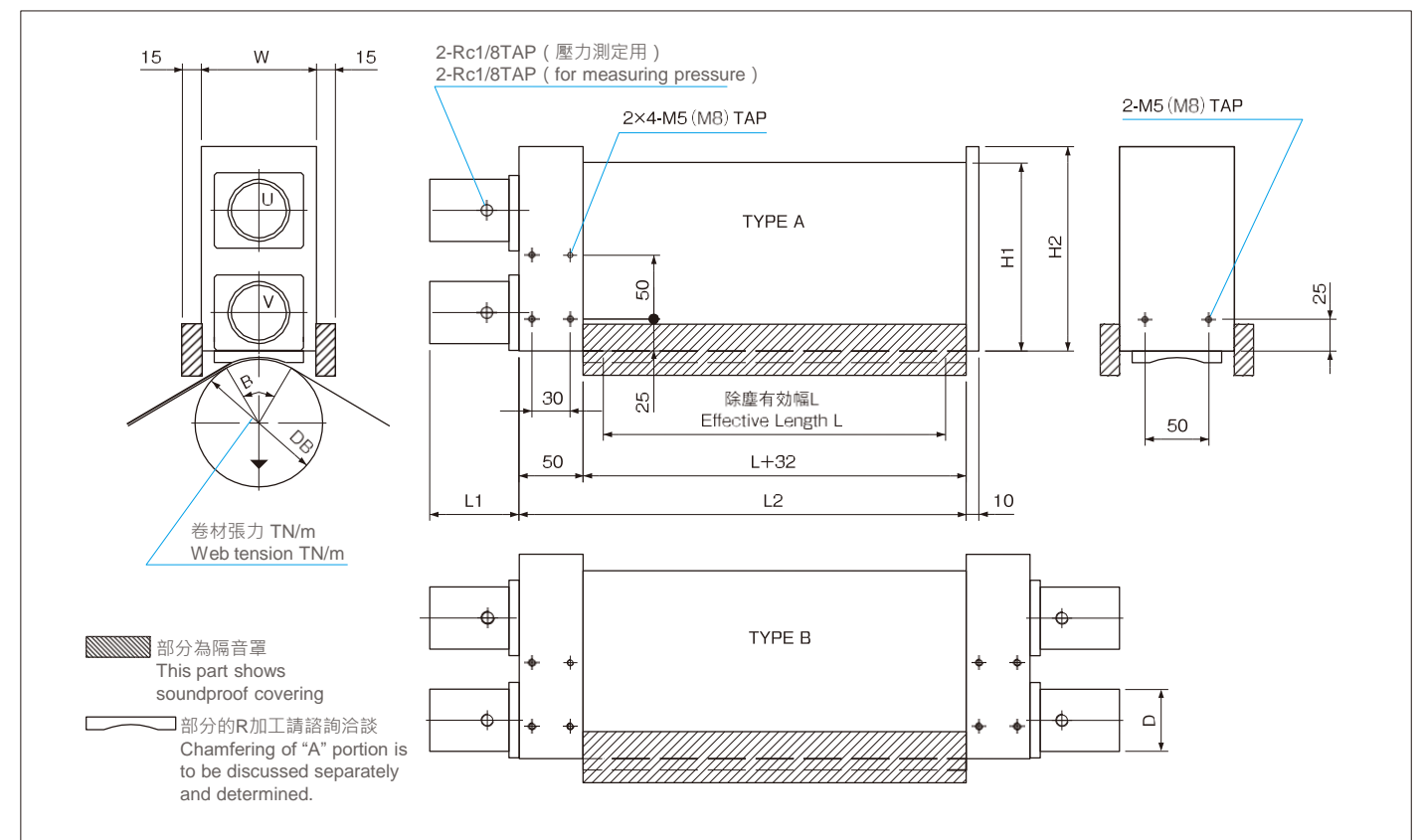

UVU-W

單位mm Unit mm

有效除塵長度L Effective Length L	類型 Type	D	L1	L2	W	H1	H2	min.DB	min.B	min.T (N/m)
50 ~ 200	A	50	70	L+92	135	161	165	φ100	46°	30
200 ~ 500	A	75	100	L+132	135	161	165	φ100	43°	30
500 ~ 900	A	90	100	L+132	135	161	200	φ113	38°	30
900 ~ 1800	B	90	100	L+132	135	196	200	φ144	38°	30
1800 ~	敬請諮詢洽談 Please consult us for details									

UVU-W-HE

單位mm Unit mm

有效除塵長度L Effective Length L	類型 Type	D	L1	L2	W	H1	H2	min.DB	min.B	min.T (N/m)
50 ~ 400	A	50	70	L+92	90	147	150	φ100	46°	30
400 ~ 900	B	50	70	L+132	90	147	150	φ113	43°	30
900 ~ 1900	B	75	100	L+132	90	147	170	φ113	43°	30
1900 ~ 3000	B	75	100	L+132	135	181	215	φ144	38°	30
3000 ~	敬請諮詢洽談 Please consult us for details									

VUV-W

單位mm Unit mm

有效除塵長度L Effective Length L	類型 Type	D	L1	L2	W	H1	H2	min.DB	min.B	min.T (N/m)
50 ~ 400	A	50	70	L+92	90	147	150	φ100	46°	30
400 ~ 1000	A	75	100	L+92	90	147	150	φ100	43°	30
1000 ~ 2000	B	75	100	L+132	90	147	170	φ113	38°	30
2000 ~ 3000	B	90	100	L+132	135	181	215	φ144	38°	30
3000 ~	敬請諮詢洽談 Please consult us for details									

VUV-W-HE

單位mm Unit mm

有效除塵長度L Effective Length L	類型 Type	D	L1	L2	W	H1	H2	min.DB	min.B	min.T (N/m)
50 ~ 500	A	50	70	L+92	90	147	150	φ100	46°	30
500 ~ 2000	B	50	70	L+132	90	147	150	φ113	38°	30
2000 ~ 3000	B	75	100	L+132	135	181	215	φ144	38°	30
3000 ~	敬請諮詢洽談 Please consult us for details.									

超音波高壓除塵 with V-port  
**VUV-HGv-W TYPE**  
 Ultrasonic High Pressure Cleaner & Ultrasonic High Pressure Cleaner with V-port

可100%除去3µm粉塵 100% Removal of 3µm particles.

除去3微米以上的粉塵，有效長度10mm~130mm(130mm以上請洽談)  
 擴大V-port面積！無空氣飛散

Remove dust 3 µm and over  
 Effective length 10 mm ~ 130 mm (Please consult us for length 130mm or above)  
 Enlarged V-port area! No air dispersing

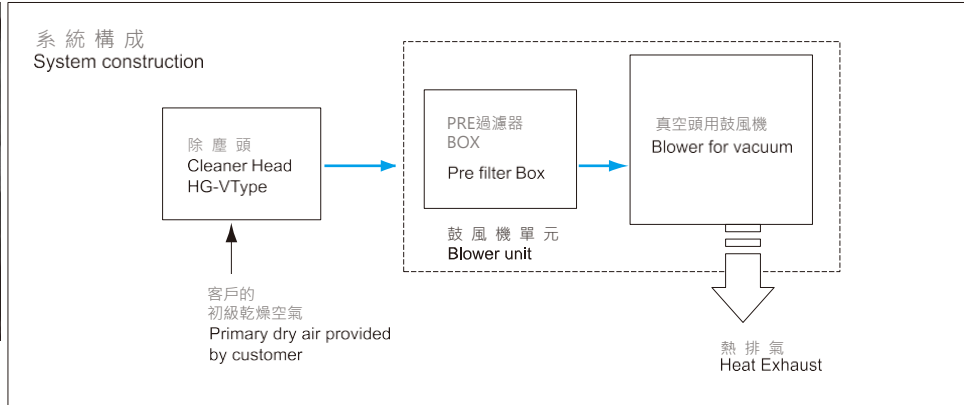
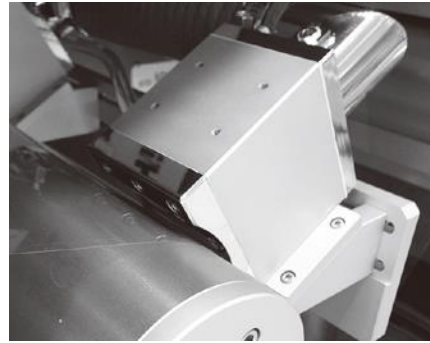

除塵原理概要 Concept

壓頭部內藏超音波發生器，使高壓高速空氣乘著超音波吹拂基材表面。不論是有空氣邊界層的頑固塵埃或是微黏性塵埃，都可藉高壓氣刀和超音波的作用將其剝離。而剝離的塵埃則藉高速空氣通過真空吸頭有效的去除。

Within the pressure head, an ultrasonic wave generating device is built-in to blow high-pressure and high-speed air flow carried by ultrasonic waves on to the substrate surface. The particle substances and even slightly adhesive dust confined firmly within the boundary layer are stripped by destruction of the boundary layer by the combination of high pressure air knife and ultrasonic wave. Stripped dust are carried by the high speed air flow and efficiently sucked into vacuum head and removed out.

外形圖 Dimensions

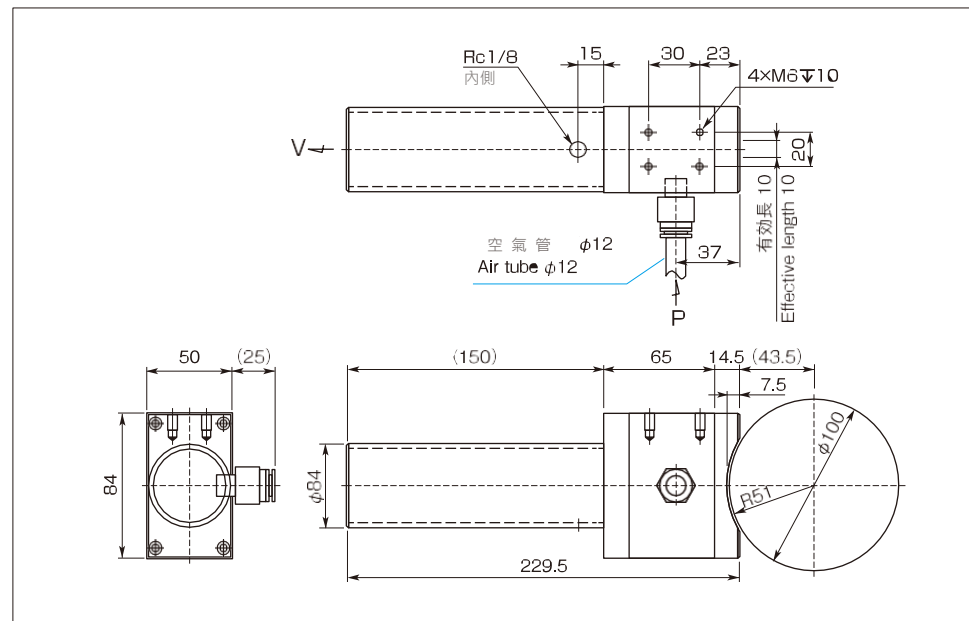

結構圖 Structure

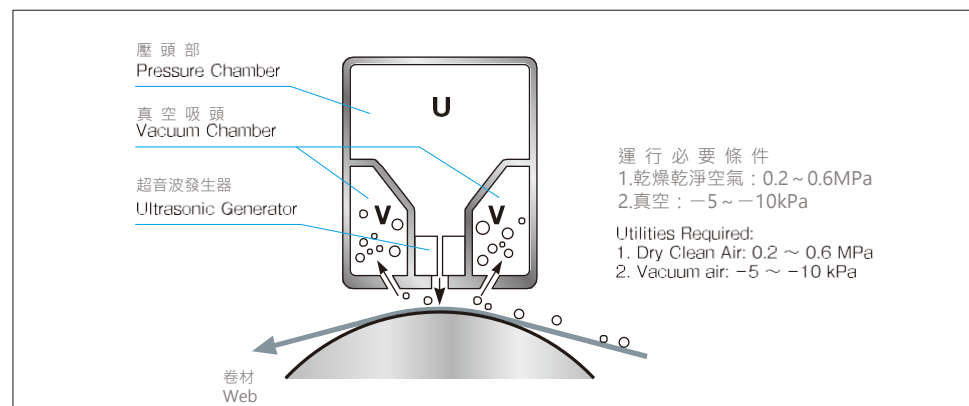

NEW **SA TYPE**

可100%除去10µm粉塵 100% Removal of 10µm particles.



1. 特長 Features

- 平板、卷材皆可對應使用
- 可去除10µm以上的粉塵
- 價格較超音波式便宜
- 有效長度可達3000mm
- Effective for flat materials and film materials.
- 10µm or bigger particles are removable.
- Lower cost compared to ultrasonic cleaners.
- Effective length available up to 2000mm.

測試結果 10µm樹脂微粒  
 Test result spray 10µm beads.



潔淨前 Before cleaning



潔淨後 After cleaning

2. 系統構成 System Configuration

- 鼓風機單元 (搭載控制、操作面板) Blower Unit with Controller
- 功能：鼓風機ON/OFF Functions
- 鼓風機轉速設定 Blower rotation speed setting
- 壓力表示 Pressure display
- 搭載過濾設備 Filters installed
- 除塵頭 SA Cleaner Head
- 附屬管線用軟管 Flexible Hose for Connection is Included.

只需將專用的鼓風機單元和管子連結起來！  
 All you need to do is to connect the blower unit and the flexible hoses!

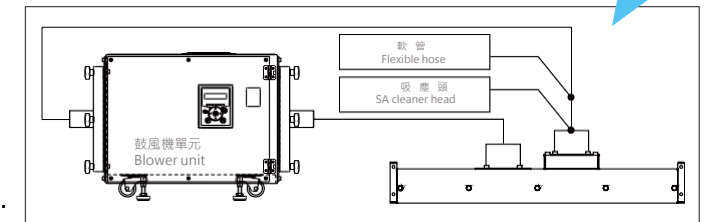

吐出、吸引之空氣通過各自的過濾器再循環。  
 Pressure and Vacuum air recirculate through the cleaning head and the two filters.

3. 運行條件 Utility

- 200~2000mm AC200V, 50/60Hz, 單相, 3kVA AC200V, 50/60Hz, Single phase, 3kVA
- 2100~3000mm AC200V, 50/60Hz, 單相, 6kVA AC200V, 50/60Hz, Single phase, 6kVA

4. 外形圖 Dimensions

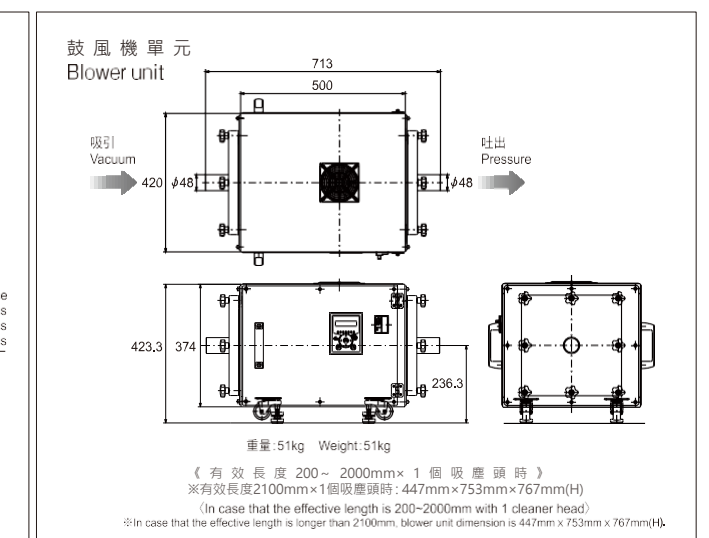
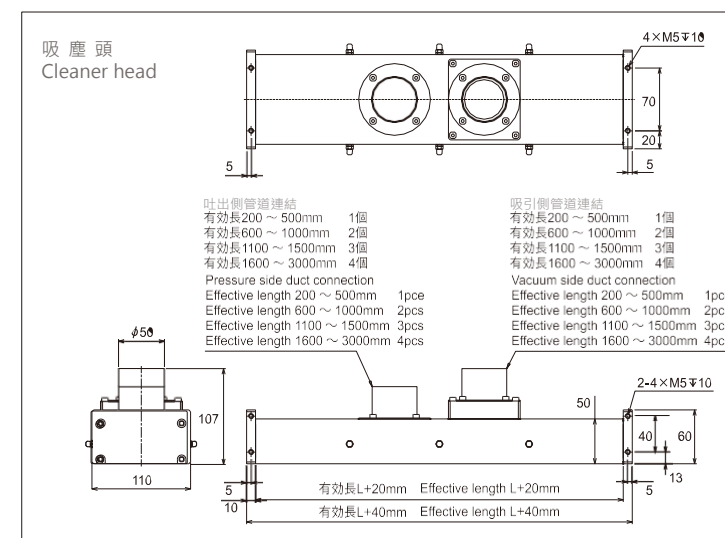

# NSHV-W TYPE

可 100% 除去 20 μm 粉塵 100% Removal of 20μm particles.

使用獨特設計吸嘴去除20微米的微粒子。物美價廉而有效的經濟型號。  
Aerodynamically Designed Vacuum Nozzle Skims Particles of 20 microns. Economical, yet Effective.

## 1. 概要 Outline of NSHV-W

使用獨特形狀(高速窄槽)吸嘴，設置在靠近卷材面的地方，在卷材上形成高速氣流，通過空氣動力曲線加速打薄邊界層並有效吸走微粒子。在卷材上比一般的工業用吸塵裝置有著更優良的除塵能力。和UVU-W型同樣為非接觸式，因此不會造成卷材刮傷或材料變性。

Air is accelerated by the aerodynamic curves of the nozzle and effectively sucks away particles. The system works far more effectively than conventional industrial vacuum cleaners when removing particles from a moving web. This system does not directly contact the substrate and, therefore, does not scratch or damage the substrate.

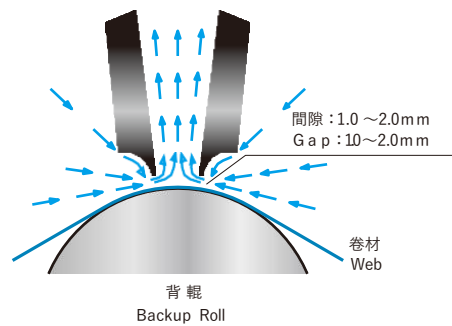

## 2. 特色 Features

- 1) 高速空氣確保高除塵性能。
  - 2) 吸嘴的除塵效果全面且均一。
  - 3) 袖珍設計，安裝便利。
  - 4) 除了過濾設備的洗淨交換外，免維護設計。
  - 5) 經濟實惠的價格。
- 1) High velocity airflow assures high cleaning performance.
  - 2) Even cleaning performance along the entire length of the head.
  - 3) Compact design for easy installation.
  - 4) Maintenance free design except for filter cleaning and replacement.
  - 5) Economical.

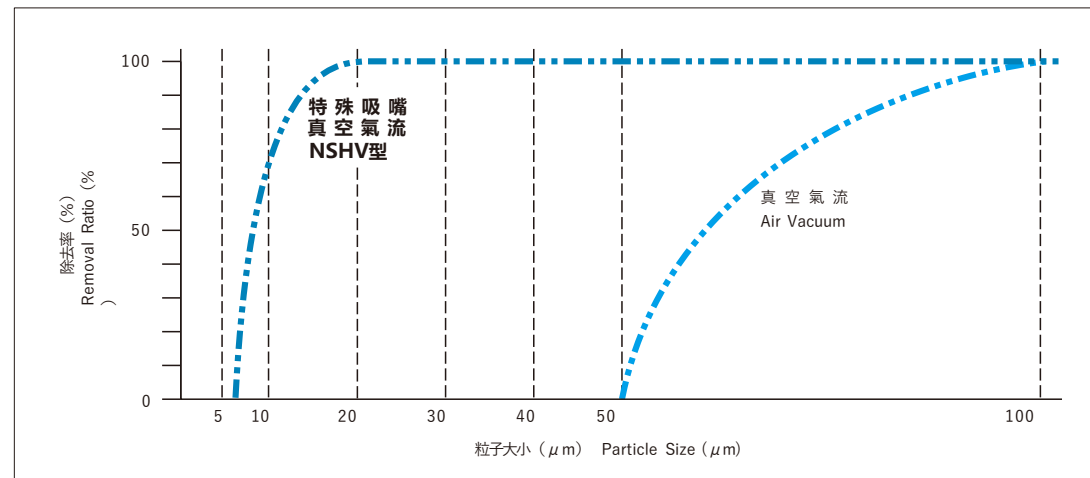

紙粉的除塵測試  
Paper dust cleaning test

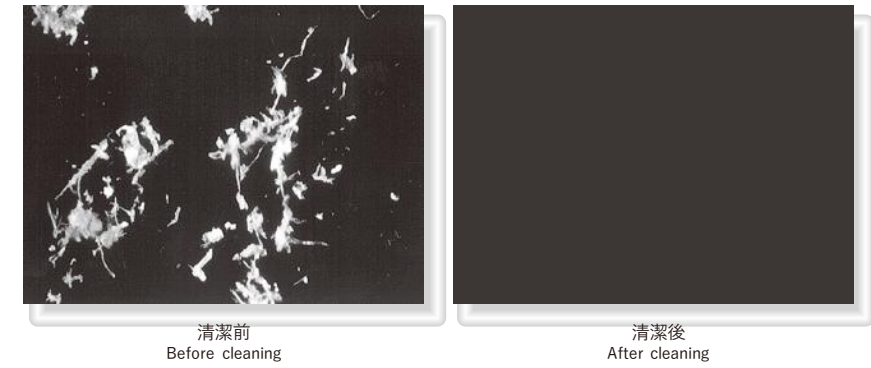

注) 測試結果是在伸與無塵室內測試得到的數據，可能會因客戶無塵室的環境、顆粒類型、測試條件等而有所不同。  
This test data is a reference data for the test carried out at SHINKO clean room.  
Test results varies according to particle types, test environments, test conditions and etc.

## 3. 配置系統與構成 Piping and Configuration

吸塵頭、PRE 過濾器、真空鼓風機、調節閥以及將各部件連結起來的管線所構成。

- 高速真空氣流將微粒子輸送至過濾器。
- 安裝在過濾器中的壓力差感知器可以告知需要更換濾芯。

The system consists of cleaner head, pre-filter, vacuum blower, damper, and hose and piping to connect these components.  
● Micro particles are transported to the filter by high velocity vacuum flow.  
● The differential pressure switch, which is mounted on the filter box, will tell the operator when to clean or replace the filter.

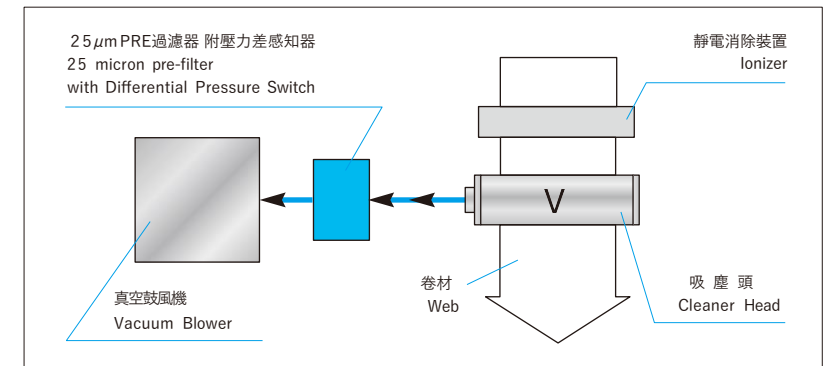

## 4. 安裝須知 Installation Tips

- 1) 除塵頭前段需要安裝消除靜電用除電電極。
  - 2) 除塵頭有效長度需要比卷長稍長。
  - 3) 除塵頭為吸氣真空式，故在無塵室中使用可能會破壞無塵室的空氣平衡。
- 1) Ionizer is necessary before the cleaner head to get rid of static electricity.
  - 2) Cleaner effective length must be longer than web length.
  - 3) The use of the vacuum system may disturb the air balance in a clean room, the air balance may be disturbed if used in a clean room.

## 5. 吸塵頭尺寸圖 Cleaner Head Dimensions

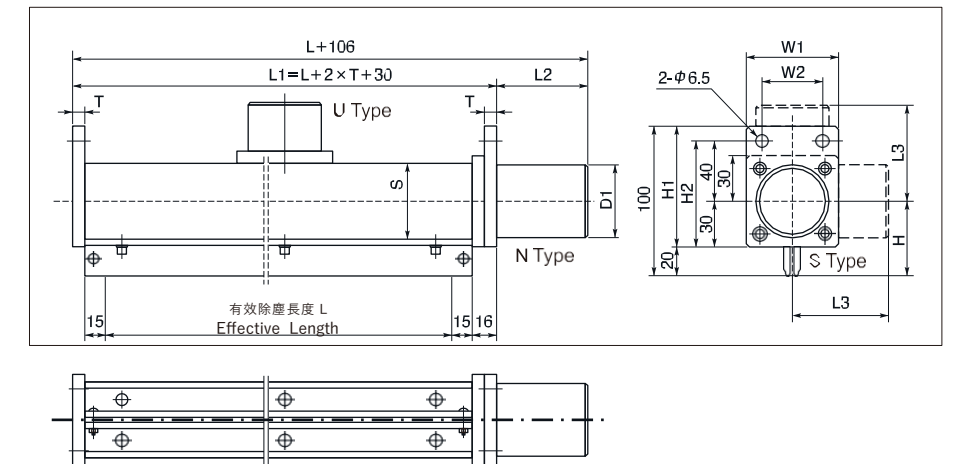

有效除塵長度 L Effective Length	類型 Type	機身尺寸 Fuselage Size	L2	D1	L3	H	T	W1	W2	H1	H2	
50 ~ 400	N1.U1.S1	□ 50	60	50	95	50	8	60	40	80	70	
400 ~ 700	N1	□ 100	敬請諮詢洽談 (可以提供圖面) Please consult us for details.									
700 ~ 1400	N2.U2.S2	□ 100										
700 ~ 900	N1	□ 150										
900 ~ 1800	N2.U2.S2	□ 150										
900 ~ 1800	N1	□ 150										
1800 ~ 3600	N2.U2.S2	□ 150										
3600 ~			敬請諮詢洽談 Please consult us for details.									

※卷材包角取決於背輥直徑和卷材張力。  
※Wrap angle of web depends on backup roll diameter and web tension.

# TURBO-SS TYPE

完全去除黏附灰塵  
Completely Remove of Adhesive Dust

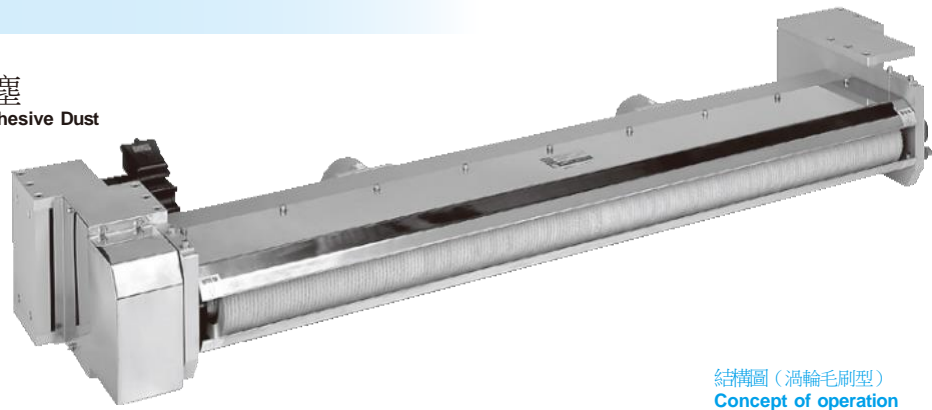

結構圖 (渦輪毛刷型)  
Concept of operation

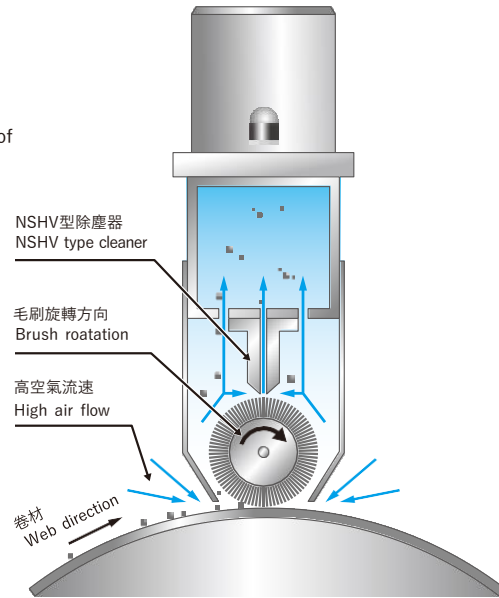

## 1. 概要 Outline

附著於基材上的黏性灰塵通過旋轉毛刷剝離清除，再經由NSHV型除塵裝置吸塵清除毛刷表面附著的灰塵。  
透過增加機殼內的風速，可以順利地將機殼內散落的灰塵吸走並順利清除。  
Tacky dusts that are sticking on materials are removed by rotating brush and dusts sticking on the surface of brush are vacuumed and removed by narrow slot nozzle.  
Dusts scattered in casing is vacuumed and removed smoothly by increasing air velocity in the casing

## 2. 特色 Features

- 1) 高速旋轉毛刷與窄槽高速真空吸引除塵器 (NSHV型) 組合而成高性能除塵設備。其優越的性能是其他公司產品所沒有的。
  - 1) 附著力強、難以清除的粉塵也能順利去除。
  - 2) 搭配NSHV型除塵器，提升除塵性能，並防止毛刷汙染。
- 1) It is the high performance dust collector by a combination of high-speed rotating brush and narrow slot high velocity vacuum cleaner. The superior performance is not seen at class to another companies.
  - 2) Even tacky and hardly removed particles can be removed.
  - 3) NSHV type cleaner can remove particles and furthermore prevent brush from contamination.

去除基材邊緣的絨毛纖維  
Remove Fibrous Hatches of Material Edges.

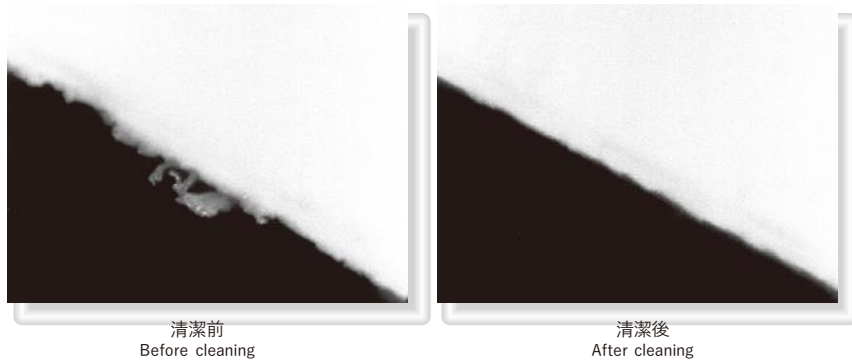

去除黏性灰塵  
Remove Tacky Dusts.

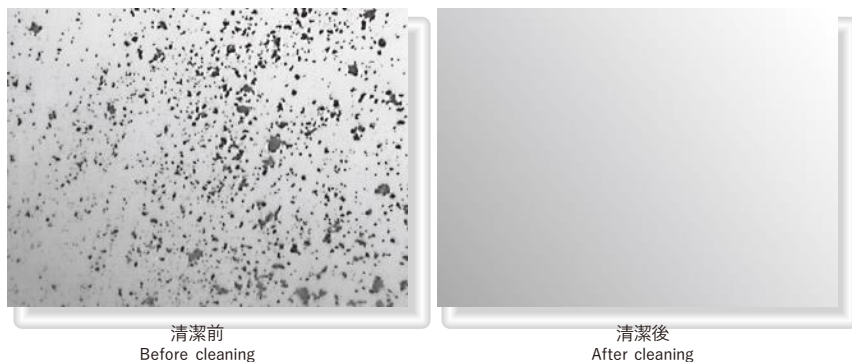

## 3. 配置系統與構成 Piping Systems and Structure

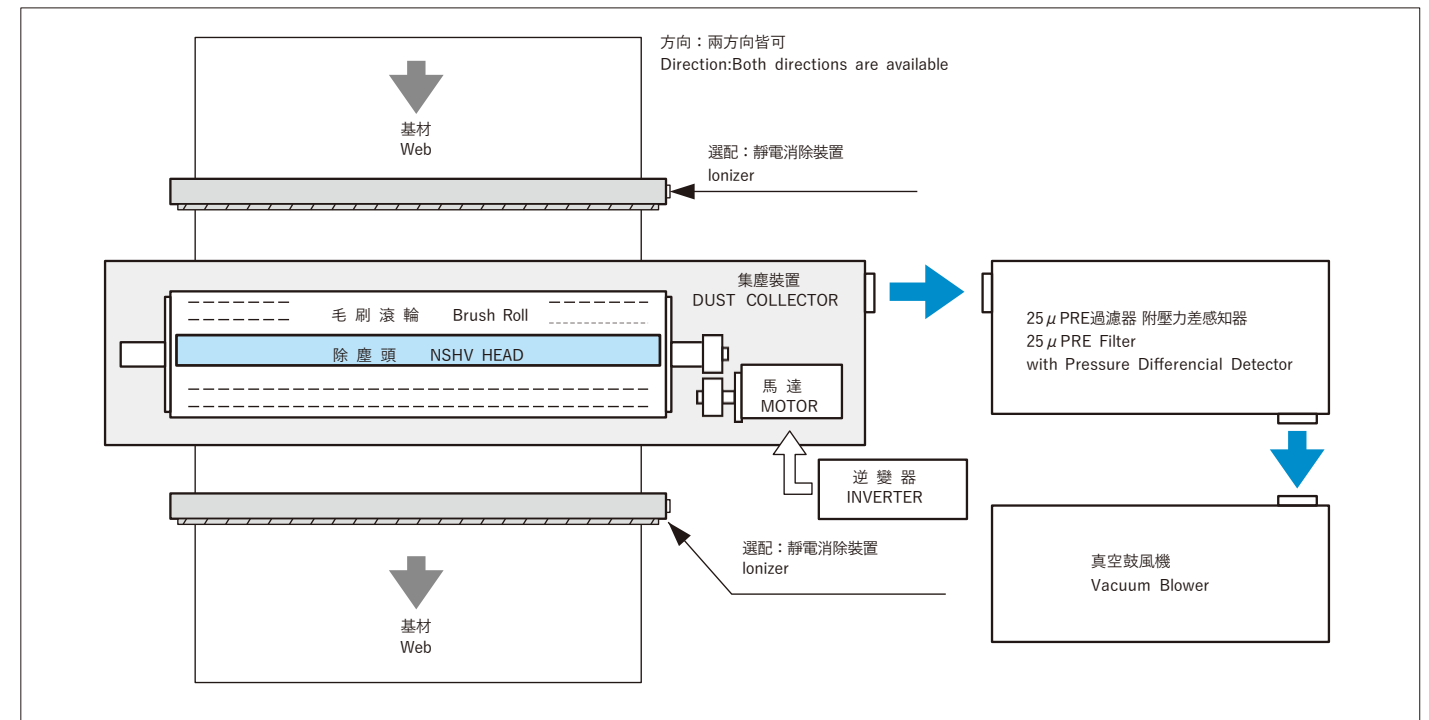

## 4. 外型圖 Dimensions

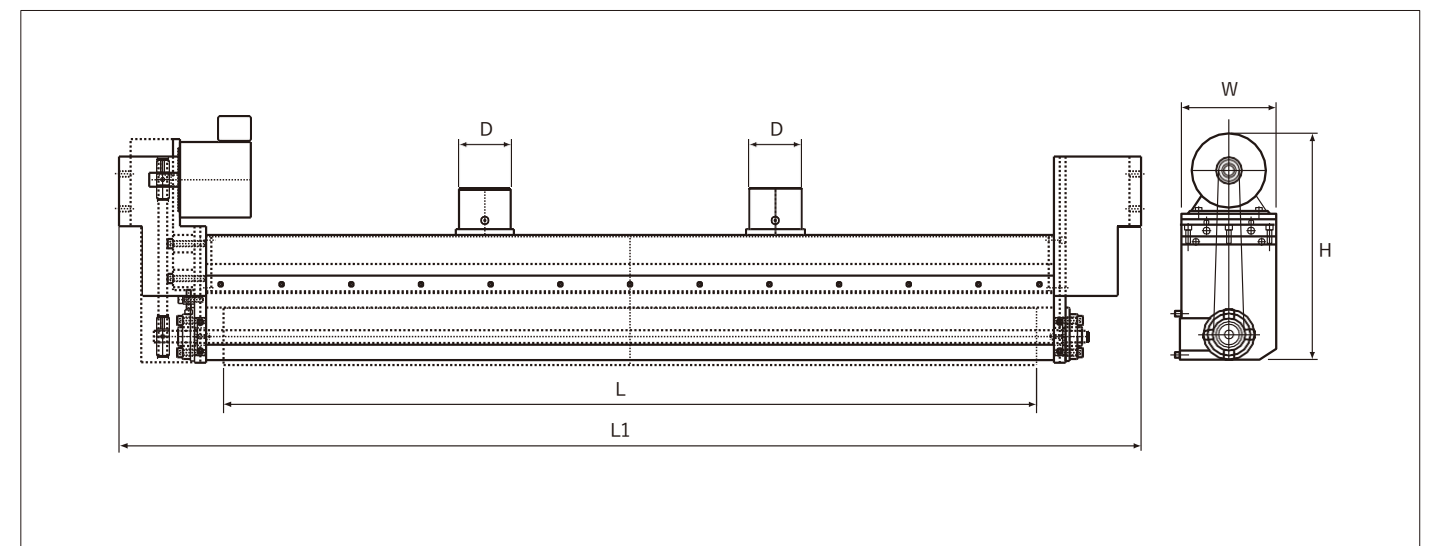

單位mm Unit mm

有效除塵長度 L Effective Length L	D	H	W	L1	毛刷直徑 Brush size	軟管接頭個數 Number of hose nipple
~400	φ50	232	100	L + 135	φ70	1
400~1,500	φ90	360	200	L + 360	φ100	2
1,500~2,500	φ125	480	200	L + 360	φ150	2
2,500~3,500	φ150	619	290	L + 375	φ200	2

※以上圖紙僅供參考。詳細請諮詢代理。※3,000mm以上也可製作。敬請諮詢洽談。  
※Above drawings are only for reference. Please ask our agents for outline drawings. ※Over 3,000mm can be manufactured. Please make an inquiry to our agents.

注) 測試結果是在伸與無塵室內測試得到的數據，可能會因客戶無塵室的環境、顆粒類型、測試條件等而有所不同。  
This test data is a reference data for the test carried out at SHINKO clean room. Test results varies according to particle types, test environments, test conditions and etc.

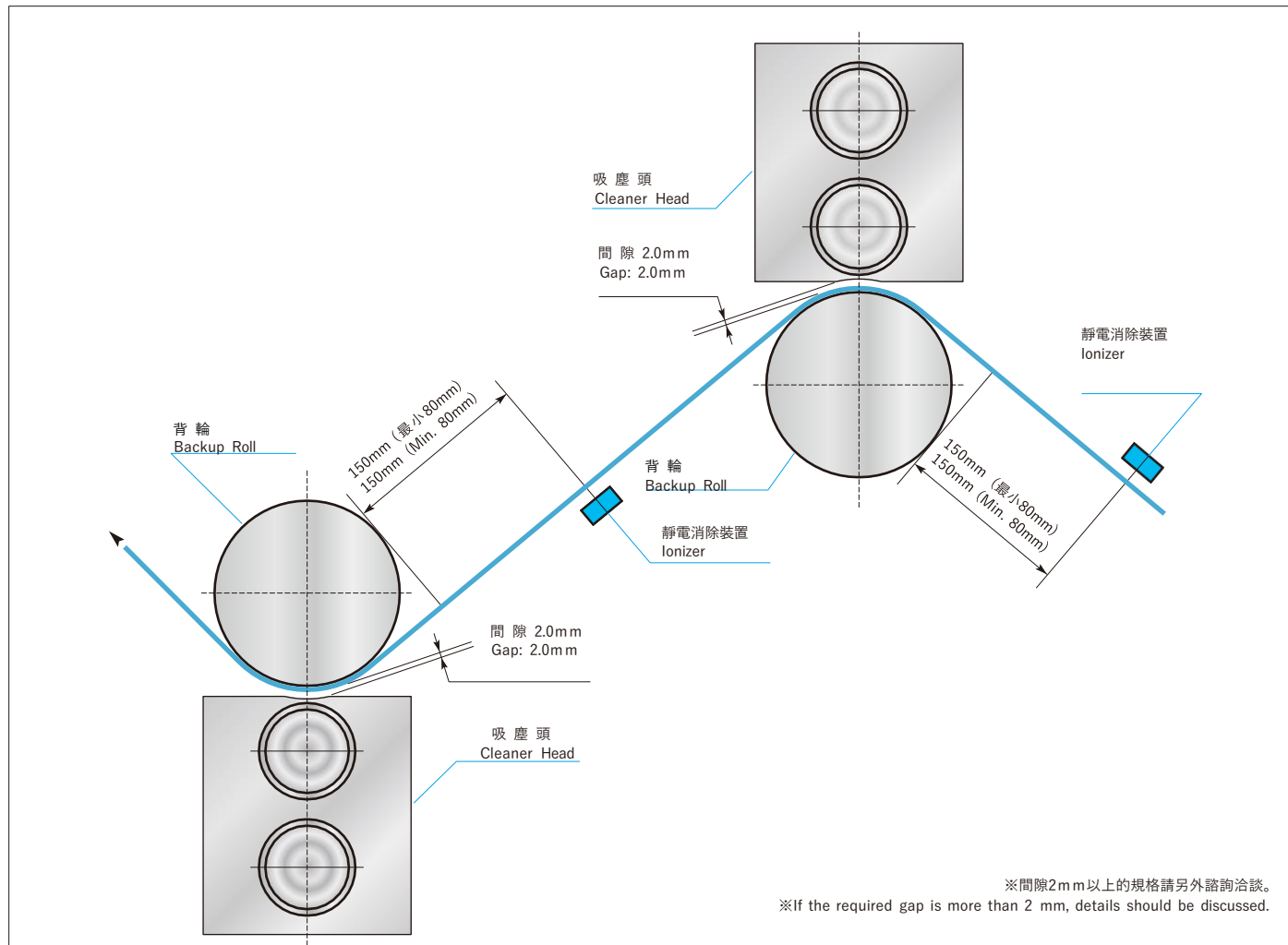

各種除塵設備的性能比較 Performance Comparisons

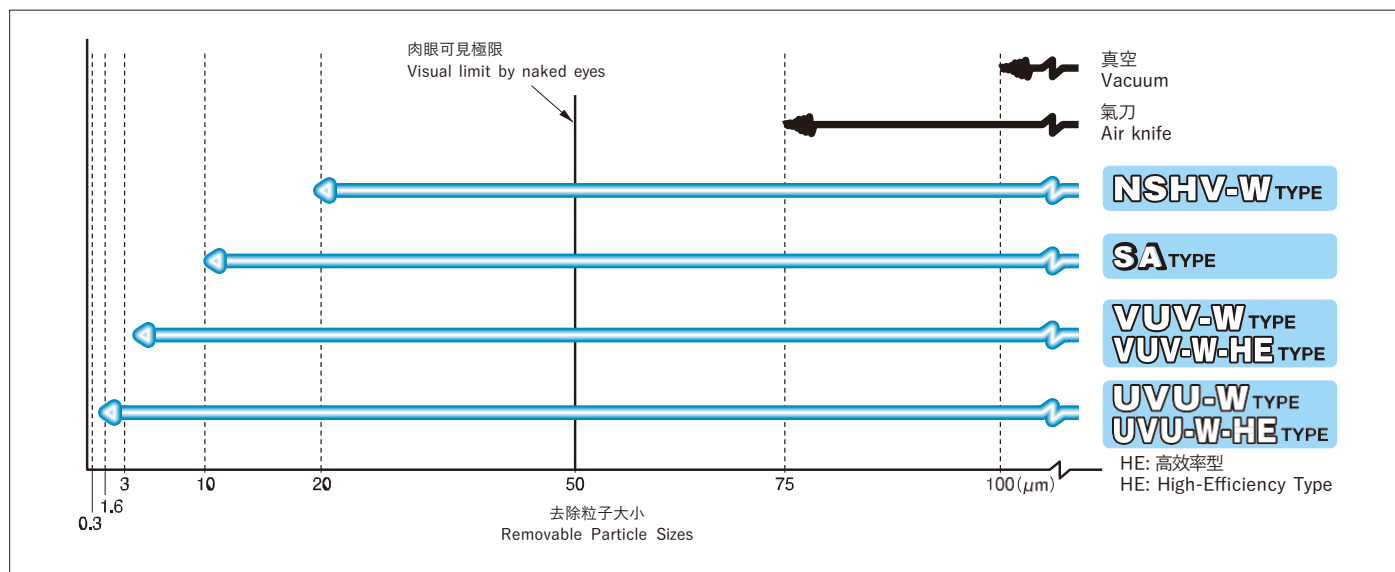

直流式除電棒:DC2型( 防爆&非防爆 )

DC Type Ionizer: DC-2 (Explosion proof or non-explosion proof)



尺寸圖 Dimensions

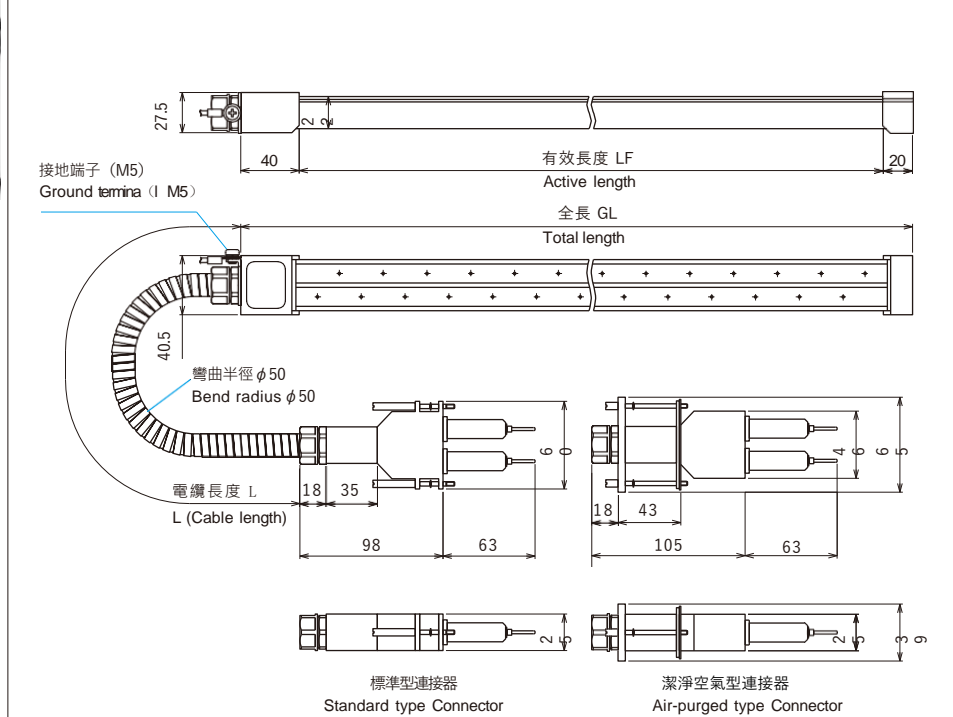

特長 Features

1. 日本首創直流式防爆型靜電消除裝置。
2. 直流式具有優秀的除電性能和除電速度。
3. 外殼採用玻璃纖維 ( FRP ) 材料、足夠堅固。
4. 電極部分採用特殊環氧樹脂、具有優異的耐溶劑性。
5. 高壓變壓器設有火花偵測電路和電極污染監測功能、可以放心使用。
6. 因為直流式、電纜與金屬接觸也不會燒損。
7. 改善塗層不均勻性。
8. 防止因靜電造成的晶鬚或墨水飛濺。

1. The first Japanese DC type EX-proof ionizing system.
2. Remarkably superior ionizing performance and speed thanks to direct current (DC).
3. Casing is tough enough using fiber glass (FRP) material.
4. Electrode portion has outstanding solvent resistance using special epoxy resin.
5. Safe operation is secured by spark detecting circuit and electrode pollution monitoring function equipped in high voltage transformer.
6. Cable of wiring along metal frame due to DC type.
7. Improving a coating uniformity.
8. Eliminating "whisker" and "color wash out" due to electrostatic hazard for gravure printing.

取得各國防爆認證

日本防爆認證編號：第56749号  
 日本防爆類型：S1G4  
 中國防爆認證編號：GYJ19.1305X  
 中國防爆類型：Ex sc IIA T4 Gc  
 PTB認證編號：NO.EX-00.Y.2601X  
 PTB防爆類型：EXS II AT6

電纜出線方向 Direction of cable outlet

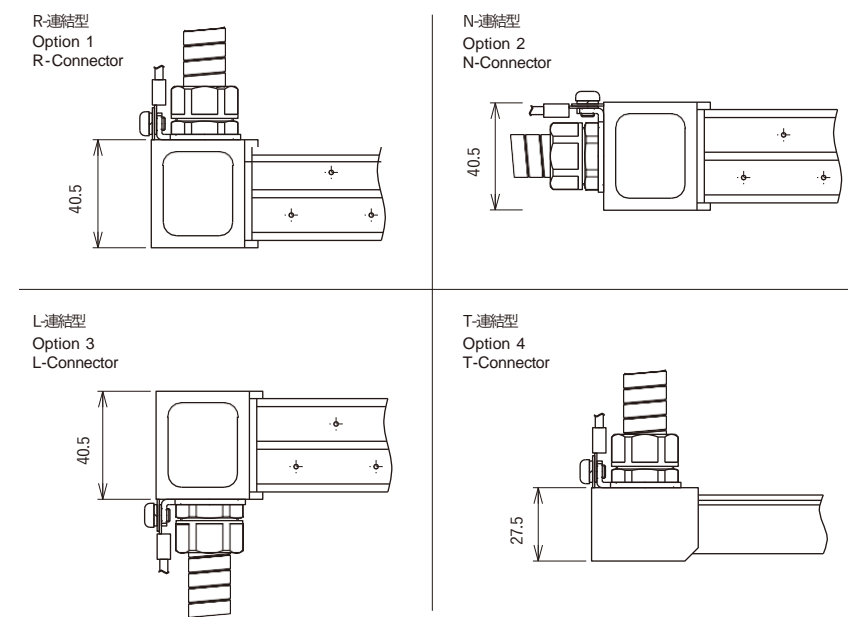



我們的 Class 100 無塵室支援大多數卷材及平板進行清潔性能測試。  
Our Class 100 cleanroom supports most web materials and flat panels for cleaning test.

在我們的無塵室中，可以對客戶帶來的基材進行性能測試。  
In our clean room, a performance test is possible on the substrates brought by our customers.



1) 測試機  
Test machine



Web 基材 ( 卷材 ) 的除塵測試機。  
( 輓面長 : 400mm )  
Cleaning test machine for web material  
(Active length: 400mm)

2) 顯微鏡  
Optical microscope



■ 顯微鏡  
Microscope

可以對各種樣本的表面進行檢查、拍照。  
適合檢查樣品的特定區域。  
A variety of samples and particles can be examined.  
Pictures can be taken.  
Suitable for examining specific areas of samples.

3) 液體中粒子計數器  
Liquid-borne Particle Counters



■ 液體中粒子計數器  
Liquid-borne Particle Counters

評估薄膜上的顆粒用裝置。  
將顆粒的大小、數量數值化呈現。  
Particle size and distribution are shown in digital format.



微粒子粒徑分布測量(液體中粒子計數器) Measurement of Particle Distribution (by Micropulser)

